

爱尔达电气有限公司

CHINA · IDEAL ELECTRIC CO., LTD.

Add: Muyu industrial zone, Wenling city, Zhejiang Province China

Tel: 0086-576-86470288

Fax: 0086-576-86471118 P.C.: 317523

E-mail: sales@zjidealmotor.com

Http://www.zjidealmotor.com

PROFESSIONAL MANUFACTURER

MOTOR

CHINA · IDEAL ELECTRIC CO., LTD.

www.zjidealmotor.com





Company Profile 公司简介

China · Ideal Electric Co., Ltd. is a professional production of various IE3 series, IE2 series, special electrical motor, adjustable speed motors, frequency conversion motor company. The company has strong technical force, not only hired a number of senior engineers, and has a number of outstanding technical personnel. Now it has more than ten production lines, modern equipment, high-tech management and advanced testing capabilities, which effectively guarantee the excellent quality of the company's products.

The company has TQC certification of the ministry of agriculture, product qualification certificate of Zhejiang bureau of quality and technical supervision, iso9001:2000 quality system certification, domestic quality certification, CCC, CQC quality system certification and many other certifications.

The company's pursuit of "science and technology for development, quality for survival" for the purpose of the enterprise. Our products sell well all over the country, and gradually in the Middle East, Europe and Southeast Asia market to win the favour of customers. We warmly welcome customers at home and abroad to negotiate business.

In order to repay your trust and support, we will provide you with the best price and the most sincere service!

中国·爱尔达电气有限公司是一家专业生产各种IE3系列、IE2系列、特种电机、调速电机、变频电机的公司。公司技术力量雄厚，不仅聘请了多名高级工程师，而且拥有一批优秀的技术人员。现拥有十余条生产流水线，现代化的设备，高科技的管理和先进的检测能力，有力保证了公司产品的优异品质。

公司拥有农业部TQC认证、浙江省质量技术监督局产品合格证、ISO9001:2000质量体系认证、国内质量认证、CCC、CQC质量体系认证等多项认证。

本公司追求“以科技求发展，以质量求生存”为企业宗旨。我们的产品畅销全国各地，并逐步在中东、欧洲和东南亚市场上赢得客户的青睐，热忱欢迎国内外客户前来洽谈业务。

为了回报您的信任和支持我们将为您提供最好的价格和最真诚的服务！

ISO9001



CERTIFICATE OF HONOR

荣誉证书

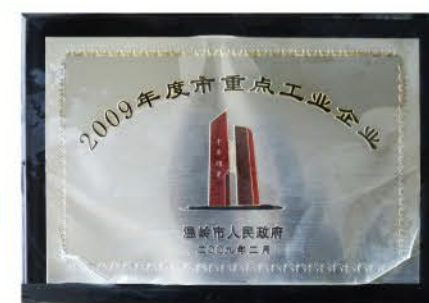

CONTENTS 目录

HIGH-EFFICIENCY THREE-PHASE ELECTRICAL MOTOR

高效三相异步电机

P07 **IE3&YE3 Series**
Three-phase electrical motors
三相异步电动机



P13 **IE2&YE2 Series**
Three-phase electrical motors
三相异步电动机



P17 **IE1 Series**
Three-phase electrical motors
三相异步电动机



P23 **YVF2 Series**
Three-phase variable frequency and
adjusting speed motor
变频调速专用三相异步电动机



P25 **YEJ2 Series**
Electromagnetic brake asynchronous motor
电磁制动三相异步电动机



P29 **YD Series**
Three-phase variable frequency and
adjusting speed motor
变频多速三相异步电动机



P45 **ANP Series**
Three-phase electrical motor
三相感应电动机



SINGLE-PHASE ELECTRICAL MOTOR

单相异步电机

P35 **YC/MC Series**
Single-phase electrical motor
变频多速三相异步电动机



P36 **YL/ML Series**
Single-phase asynchronous motor
电容启动异步电动机



P37 **MY Series**
Single-phase asynchronous motor
单相异步电动机



P57 **JY Series**
Single-phase electrical motor
单相电容感应电动机



P59 **MCBV Series**
Single-phase capacitor electrical motor
单相电容感应电动机



SPECIAL ELECTRICAL MOTOR

配套专用电机

P39 **TYP Series**
Variable frequency drive permanent
magnet synchronous motor
变频驱动永磁同步电动机



P41 **IP23 Series**
Three-phase electrical motor
三相感应电动机



P49 **YCT Series**
Three-phase speed-adjusting
electromagnetic motor
三相调速调校电磁电机



P51 **YB2 Series**
Explosion-proof Three-phase
electrical motor
防爆三相异步电动机



P60 **Industrial Fan**
超大型节能工业风扇



P61 **ZWY Series**
Brushless motor
无刷电机



工作制Duty Cycle:

S1 连续工作制 Continuous Duty	在额定负载下的运作时间足以达到热稳定。 Operating time at rated load is sufficient to achieve thermal stability
S2 短时工作制 Short-Time Duty	在恒定负载下按给定的时间运行, 该时间不足以达到热稳定, 随之即断能停转足够时间, 使电机再度冷却到与冷却介质温度之差在2k以内。 Running at a given time under a constant load, the time is not enough to achieve thermal stability. Then turn off the power to cool the motor temperature and make sure the difference with the cooling medium is within 2k.
S3 断续周期工作制 Intermittent Periodic Duty	按一系列相同的工作周期运行, 每一周期包括一段恒定负载运行时间和一段断能停转时间。这种工作制中的每一周期的起动电流不会对温升产生显著影响。 According to a series of the same cycle of operation, each cycle includes a constant load operation time and a breakdown time. The starting current of each cycle in this system has no significant effect on temperature rise.
S4 包括起动的断续周期工作制 Intermittent Periodic Duty	按一系列相同的工作周期运行, 每一周期包括一段对温升有显著影响的起动时间, 一段恒定负载运行时间和一段断能停转时间。 According to a series of the same cycle of operation, each cycle includes a period of starting time which has a significant influence on temperature rise, a period of running time with constant load and a period of breakdown time.
S5 包括电制动的断续周期工作制 Intermittent Periodic Duty	按一系列相同的工作周期运行, 每一周期包括一段起动时间, 一段恒定负载运行时间, 一段快速电制动时间和一段断能停转时间。 According to a series of the same cycle of operation, each cycle includes a period of starting time, a period of constant load running time, a period of rapid electric braking time and a period of breakdown time.
S6 连续周期工作制 Continuously Operation With Cyclic Load	按一系列相同的工作周期运行, 每一周期包括一段恒定负载运行时间和一段空载运行时间, 但无断能停转时间。 According to a series of the same cycle of operation, each cycle includes a period of constant load running time and a period of no-load running time, but there is no outage running time.
S7 包括电制动的连续周期工作制 Intermittent Periodic Duty with Starting and Braking	按一系列相同的工作周期运行, 每一周期包括一段起动时间, 一段恒定负载运行时间, 一段快速电制动时间, 但无断能停转时间。 According to a series of the same cycle of operation, each cycle includes a period of starting time, a period of constant load running time and a period of rapid electric braking time, but there is no outage running time.
S8 包括变速变负载的连续周期工作制 Intermittent Periodic Duty with pole Changing	按一系列相同的工作周期运行, 每一周期包括一段在预定转速下恒定负载运行时间, 和一段或几段在不同转速下的其它恒定负载的运行时间, 但无断能停转时间。 According to a series of the same cycle of operation, Each cycle includes a period of running time under a constant load at a predetermined speed, and a period or periods of running time under other constant loads at different speeds, but here is no outage running time.

MECHANICAL FEATURES 机器特性

HOUSING, END SHIELDS AND FLANGES

机壳、端罩和凸缘

Materials of frames, covers and flanges used in IDEAL ELECTRIC are summarized in the following table.

下表总结了爱尔达电气制作电机时使用的机壳、端盖和凸缘的材料;

电机尺寸 Frame Size	机壳 Housings	端罩 Covers	B5	凸缘 Flanges B14 ST	特种 B14 Special
63					
71	铝	铝	铝	铝	生铁
80	Aluminum	Aluminum	Aluminum	Aluminum	Cast Iron
90					
100					
112					
132	铝或铁	铝或铁	铝或铁	铝或铁	生铁
	Aluminium or cast Iron	Aluminium or cast Iron	Aluminium or cast Iron	Aluminium or cast Iron	Cast Iron
160					
180					
200	生铁	生铁	生铁		
225	Cast Iron	Cast Iron	Cast Iron		
250					
280					
315					

安装结构型式 Construction and mounting type

结构型式 Construction type	驱动端盖不带凸缘 With feet and without flange on the endshield(DE)					
安装型式 Mounting type	IM B3 FS 80~355	IM B6 FS 80~160	IM B7 FS 80~160	IM B8 FS 80~160	IM V5 FS 80~225	IM V6 FS 80~225
示意图 Diagram						

结构型式 Construction type	机座不带底脚, 驱动端盖带凸缘 Without feet and with flange on the endshield(DE)			机座带底脚, 驱动端盖带凸缘 With feet and with flange on the endshield(DE)		
	安装型式 Mounting type	IM B3 FS 80~355	IM B6 FS 80~160	IM B7 FS 80~160	IM B8 FS 80~160	IM V5 FS 80~225
示意图 Diagram						

电机常见故障及排除方法

故障	可能的原因	检查或校正方法
电动机空载时不能启动	<ol style="list-style-type: none"> 1. 馈电路断线 (三相当中的一根) 2. 定子三相绕组中的一相断路 ("Y"形连接时) 3. 电源电压或频率不对 	<ol style="list-style-type: none"> 1. 检查电源电压和个别连接处。 2. 检查保险丝, 馈电线内电流和每一相绕组的电阻。 3. 检查电压及频率。
电动机在负载时不能启动, 在低负载或空载时能启动, 但在负载增加后转速即大跌或甚至停下来	<ol style="list-style-type: none"> 1. 电源电压低 2. 定子绕组有匝间短路 3. 定子三相绕组中异相断线 ("Δ"接线法时) 4. 过载 	<ol style="list-style-type: none"> 1. 检查线路电压。 2. 检查每相绕组和每相空载电流。 3. 检查每组绕组电阻。 4. 检查负载。
电机停留在低转速	<ol style="list-style-type: none"> 1. 定子绕组一相接反, 电动机发声音 2. 转子端环和导杆中间有断裂情况 	<ol style="list-style-type: none"> 1. 检查馈电线的电流和引出线标记。 2. 检查短路电流。
定子过热	<ol style="list-style-type: none"> 1. 馈电线路三根中有一根断线或定子绕组一相断路 2. 电源电压过大或过低 3. 过载 4. 定子匝间相同或短路 5. 通风不好 	<ol style="list-style-type: none"> 1. 检查保险丝, 线间电压和导线电流。 2. 检查馈电线内的电流, 检查定子相间和对地绝缘电阻。 3. 检查绕组电阻, 检查通风孔道。
轴承过热	<ol style="list-style-type: none"> 1. 装配不对 2. 电动机轴与被拖动物之轴不平行 3. 没有润滑油, 油内有杂物或油质不良 4. 皮带过紧 5. 不平衡的磁性吸力大 	<ol style="list-style-type: none"> 1. 检查转子是否容易转动。 2. 校正两轴平衡。 3. 更换润滑油。 4. 松皮带或移动底脚。 5. 检查空气隙偏心率。
合闸时保险设备跳闸	<ol style="list-style-type: none"> 1. 定子绕组一相接反 2. 把应当接成"Y"形的定子三相绕组接成"Δ"形 3. 绕组对机座短路或相间短路 	<ol style="list-style-type: none"> 1. 检查引出线标记和接法。 2. 检查各相绕组对机座的绝缘以及相同绝缘。
机械振动过大	<ol style="list-style-type: none"> 1. 转子不平衡只在相当低的转速时才不振动 2. 轴向窜动大 3. 传动皮带接头接得不好 4. 皮带轮不平稳 	<ol style="list-style-type: none"> 1. 检查平衡情况。 2. 检查轴承外的间隙, 并加以调整。重新接皮带。 3. 检查皮带轮。

注: 电动机的故障及产生的故障的原因很多, 有时一个故障可能有几个原因, 一个原因也可以产生几种故障, 上表所列仅为常见的几种, 在检查如发生疑问可参阅有关检修维护书或与制造厂联系。

Common malfunctions and solutions

Stoppage	Possible reasons	Check or calibration methods
No-load motor can't start	<ol style="list-style-type: none"> 1. The feeder is disconnected (one root of the three phase) 2. One phase break in the three-phase winding of the stator (Connected in "Y" shape) 3. Power supply voltage or frequency is wrong 	<ol style="list-style-type: none"> 1. Check the supply voltage and individual connections. 2. Check the fuses, current in the feeder and resistance of each phase winding. 3. Check voltage and frequency.
The motor cannot start under load but can start at low load or no load. When the load increases, the speed drops sharply or even stop	<ol style="list-style-type: none"> 1. Low power supply 2. Stator windings have inter-turn short circuit 3. Out-of-phase disconnection in stator three-phase winding ("Δ" wiring method) 4. overload 	<ol style="list-style-type: none"> 1. Check the line voltage. 2. Check each winding and no-load current of each phase. 3. Check the resistance of each winding. 4. Check the load.
Motor stay in low rotation speed	<ol style="list-style-type: none"> 1. one phase of the stator winding backwards, motor create sounds. 2. the rotor end ring and middle of the guide rod cracked. 	<ol style="list-style-type: none"> 1. Check the current of the feeder and the extension line marks. 2. Check short circuit current.
Stator overheating	<ol style="list-style-type: none"> 1. One of the three feeder lines is broken or one phase of the stator winding is broken 2. The power supply voltage is too high or too low 3. overload 4. Stator turns are identical or short cut 5. Poor ventilation 	<ol style="list-style-type: none"> 1. Check for fuses, interline voltages and lead currents. 2. Check the current in the feeder; 3. Check the stator phase and ground insulation resistance. 4. Check the winding resistance. Check the vents.
Bearing overheating	<ol style="list-style-type: none"> 1. Wrong assembly 2. The motor shaft is not parallel to the axis being dragged 3. No lubricating oil, sundries or poor oil quality 4. The belt is too tight 5. unbalanced magnetic suction 	<ol style="list-style-type: none"> 1. Check whether the rotor rotates easily. 2. Calibrate two axis balance. 3. Change the oil. 4. Loosen the belt or move the foot. 5. Check air gap eccentricity.
Safety device trip during closing	<ol style="list-style-type: none"> 1. The stator winding is inversely connected 2. Wrongly form three-phase winding of the stator from "Y" to "Δ" shape 3. winding short circuit to the base or phase short circuit 	<ol style="list-style-type: none"> 1. Check extension line marks and connection. 2. Check the insulation of each phase winding to the frame as well the same insulation.
Excessive mechanical vibration	<ol style="list-style-type: none"> 1. Rotor imbalanced and only stable at a fairly low speed 2. Excessive axial movement 3. the transmission belt joint is not well connected 4. The pulley is not stable 	<ol style="list-style-type: none"> 1. Check the balance. 2. Check the outer clearance of the bearing and adjust it. 3. Reconnect the belt. 4. Check the pulley.

Note: There are many reasons for the malfunctions, sometimes there might be several reasons for one proble, somet mes one reason might came several problem. These listed in the table are just those frequent appeared, please don'thesitate to contact us while in need

PRODUCT STRUCTURE DISPLAY

产品解析

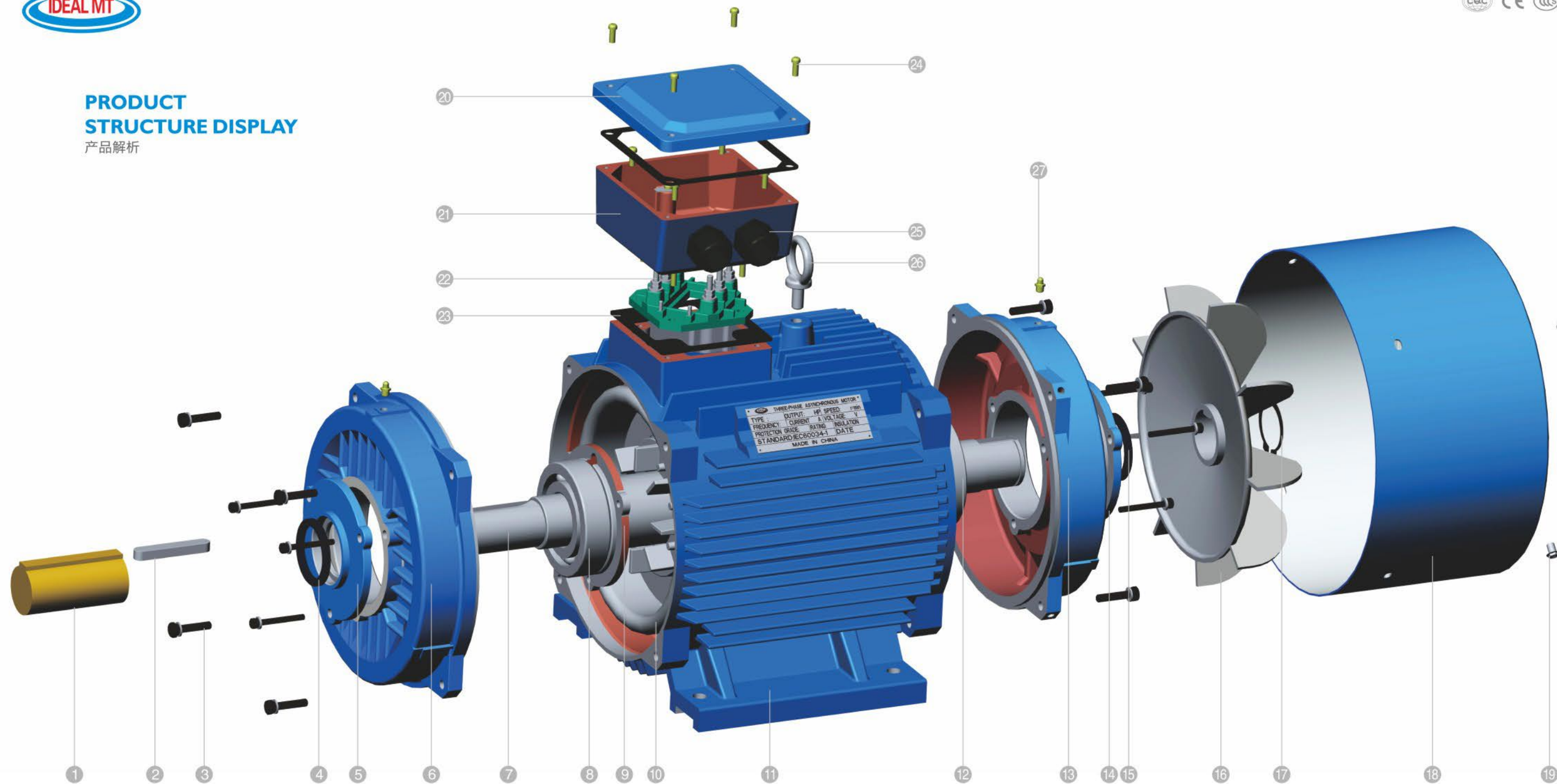

① Bearing Cap 轴套

② Key 方销

③ Hex screw 外六角螺丝

④ Oil seal 油封

⑤ Endshield D.E 驱动端端盖

⑥ Anterior end cover 前端盖

⑦ Rotor Shaft 转子轴

⑧ Bearing 轴承

⑨ Inner bearing cap D.E 驱动端轴承内盖

⑩ Stator lamination pack 定子铁芯

⑪ Frame 机座

⑫ Bearing 轴承

⑬ Rear end cover 后端盖

⑭ Out bearing cap N.D.E 驱动端端盖外盖

⑮ Oil seal 油封

⑯ Fan 风叶

⑰ Circlip 卡簧

⑱ Fan cover 风罩

⑲ Cross hexagon Screw 十字六角螺丝

⑳ Terminal box cap 接线盒盖

㉑ Terminal box base 接线盒座

㉒ Binding post 接线柱

㉓ Rubber cushion 皮垫

㉔ Cross screw 十字六角螺丝

㉕ Threaded sleeve 螺套

㉖ Rings 吊环

㉗ Zerk 加油嘴

三相异步电动机

IE3&YE3

Three-phase Electrical motors

三相异步电动机

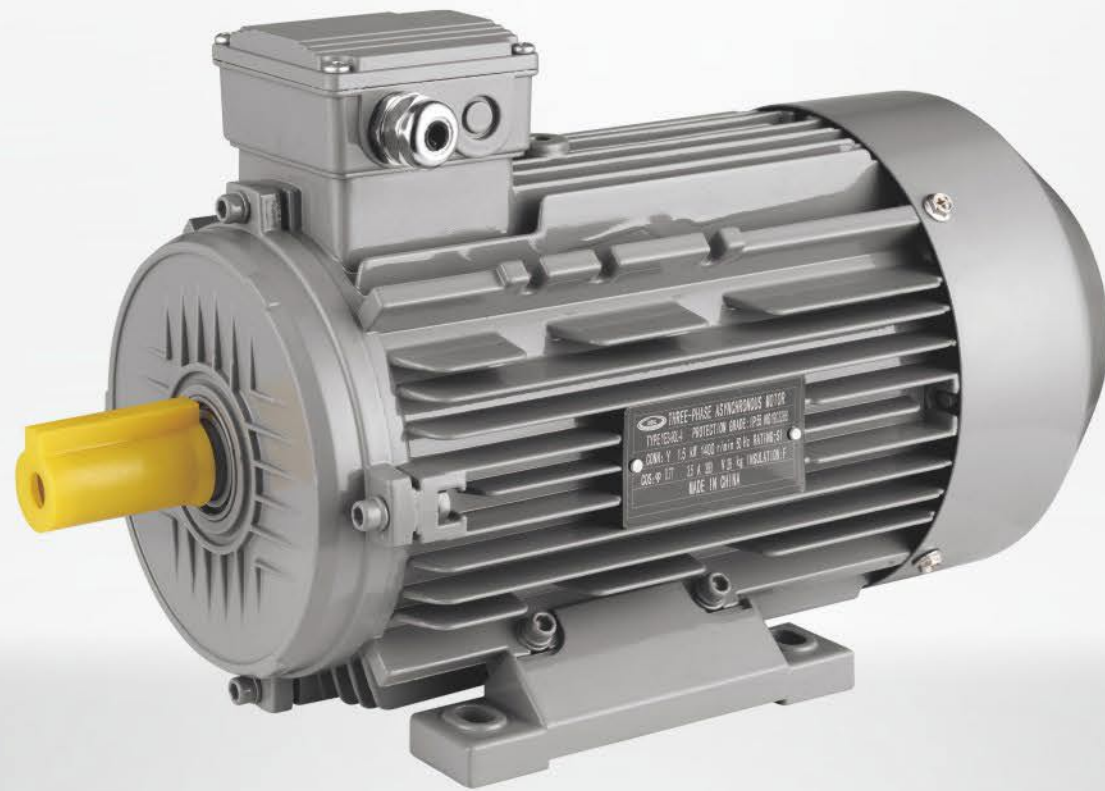

IE3系列三相异步电动机符合IEC60034-30:2008标准的IE3能效等级。

IE3系列三相异步电动机的安装尺寸符合IEC60034标准，具有结构合理，外表美观、噪声低、防护等级高、绝缘等级高等优点，可广泛应用于风机、水泵、机床、压缩机、运输机械等各种通用机械设备，也可在石油、化工、钢铁、矿山等其他环境比较恶劣的场所使用。

IE3 series three-phase asynchronous motors meet IE3 energy efficiency level in IEC60034-30:2008 standard.

IE3 series three-phase asynchronous motors are installed in accordance with IEC60034 standard. They have the advantages of reasonable structure, beautiful appearance, low noise, high protection level and high insulation level. They can be widely used in fans, pumps, machine tools, compressors, transport machinery and other general mechanical equipment. They can also be used in petroleum, chemical, iron and steel, mines and other places where the environment is harsh.

TECHNICAL DATA 技术参数

IE3&YE3

Type 型号	Rated Output 功率		Rated Speed 转速 (r/min)	Eff 效率 (%)	Power Factor 功率因数 (cosφ)	Current 电流 (A)			Rated Torque 额定转矩 (r/min)	堵转转矩 额定转矩 T _{st} /T _n	最大转矩 额定转矩 T _{max} /T _n	堵转电流 额定电流 I _{st} /I _n
	Kw	Hp				380V 50Hz	400V 50Hz	415V 50Hz				
801-2	0.75	1	2875	80.7	0.83	1.77	1.68	1.62	2.49	2.5	3	5.3
802-2	1.1	1.5	2875	82.7	0.84	2.50	2.37	2.29	3.65	3.2	3.8	7
90S-2	1.5	2	2890	84.2	0.84	3.32	3.16	3.04	4.96	2.7	3.5	7.1
90L-2	2.2	3	2890	85.9	0.85	4.72	4.48	4.32	7.27	2.4	3	6.9
100L-2	3	4	2891	87.1	0.87	6.17	5.86	5.65	9.91	3.2	4	8.0
112M-2	4	5.5	2914	88.1	0.88	8.04	7.64	7.36	13.11	2.5	3	7.5
132S1-2	5.5	7.5	2937	89.2	0.86	11.2	10.6	10.2	17.88	2.7	3.5	7.5
132S2-2	7.5	10	2940	90.1	0.88	14.6	13.9	13.4	24.36	2.4	3.3	7.5
160M1-2	11	15	2930	91.2	0.89	21.0	19.9	19.2	35.85	2.2	2.9	7.6
160M2-2	15	20	2930	91.9	0.89	28.4	26.9	26.0	48.89	2.3	3	7.6
160L-2	18.5	25	2937	92.4	0.89	34.7	33.0	31.8	60.15	2.3	3.1	7.4
180M-2	22	30	2940	92.7	0.88	41.6	39.5	38.1	71.12	2.8	3.2	7.8
200L1-2	30	40	2950	93.3	0.88	56.2	53.4	51.5	97.12	2.6	3	7.8
200L2-2	37	50	2950	93.7	0.89	68.2	64.8	62.5	119.78	2.6	3	7.7
225M-2	45	60	2960	94.0	0.89	82.5	78.4	75.6	145.19	2.4	2.6	7.5
250M-2	55	75	2965	94.3	0.90	99.5	94.5	91.1	177.15	2.3	2.8	7.1
280S-2	75	100	2970	94.7	0.90	135	128	123	241.16	2.5	2.8	7.4
280M-2	90	125	2970	95.0	0.91	160	152	146	289.39	2.8	2.8	7.6
315S-2	110	150	2975	95.2	0.91	194	185	178	353.11	2.4	2.8	6.9
315M-2	132	180	2975	95.4	0.91	233	221	213	423.73	2.6	2.9	7.1
315L1-2	160	200	2975	95.6	0.92	278	265	255	513.61	2.5	2.9	7.1
315L2-2	200	270	2975	95.8	0.92	348	330	318	642.02	2.5	2.8	6.9
355M-2	250	340	2980	95.8	0.92	434	412	398	801.17	2.5	2.8	7
355L-2	315	430	2980	95.8	0.92	547	520	501	1009.48	2.5	2.9	7

三相异步电动机

TECHNICAL DATA 技术参数

IE3&YE3

Type 型号	Rated Output 功率		Rated Speed 转速 (r/min)	Eff 效率 (%)	Power Factor 功率因数 (cosφ)	Current 电流 (A)			Rated Torque 额定转矩 (r/min)	堵转转矩 额定转矩 T _{st} /T _n	最大转矩 额定转矩 T _{max} /T _n	堵转电流 额定电流 I _{st} /I _n
	Kw	Hp				380V 50Hz	400V 50Hz	415V 50Hz				
802-4	0.75	1	1400	82.5	0.76	1.88	1.78	1.72	5.12	2.4	2.9	5
90S-4	1.1	1.5	1440	84.1	0.77	2.66	2.53	2.44	7.3	3	3.5	6
90L-4	1.5	2	1445	85.3	0.77	3.57	33.9	3.27	9.91	3.2	3.8	6.8
100L1-4	2.2	3	1440	86.7	0.81	4.88	4.64	4.47	14.6	3	3.5	7
100L2-4	3	4	1440	87.7	0.82	6.50	6.18	5.95	19.9	2.6	3.3	7
112M-4	4	5.5	1445	88.6	0.82	8.55	8.12	7.83	26.4	3.5	4	7.5
132S-4	5.5	7.5	1455	89.6	0.83	11.5	10.9	10.5	36.1	2.2	2.8	6.4
132M-4	7.5	10	1455	90.4	0.84	15.3	14.5	14.0	49.2	2.4	3	7
160M-4	11	15	1460	91.4	0.84	22.1	21.0	20.3	71.9	2.5	2.9	6.9
160L-4	15	20	1460	92.1	0.85	29.6	28.1	27.1	98.1	2.5	3	7.5
180M-4	18.5	25	1470	92.6	0.86	35.8	34.0	32.8	120.2	2.6	3.1	7.8
180L-4	18.5	25	1470	93.0	0.86	35.8	34.0	32.8	120.2	2.6	3.1	7.8
200L-4	30	40	1470	93.6	0.86	57.3	54.4	52.5	194.9	2.4	2.9	7.1
225S-4	37	50	1480	93.9	0.87	69.7	66.2	63.8	238.8	2.5	2.7	7.5
225M-4	45	60	1480	94.2	0.87	84.3	80.1	77.2	290.4	2.5	2.8	7.6
250M-4	55	75	1480	94.6	0.87	103	97.5	94.0	354.9	2.6	2.7	7.3
280S-4	75	100	1480	95.0	0.87	139	132	127	484	2.7	2.7	7.6
280M-4	90	125	1480	95.2	0.87	167	158	153	580.7	2.7	2.7	7.5
315S-4	110	150	1485	95.4	0.88	201	191	184	707.4	2.7	2.9	7.1
315M-4	132	180	1485	95.6	0.88	240	228	220	848.9	2.7	2.9	7.3
315L1-4	160	200	1485	95.8	0.89	288	273	263	1029	3	3	7.4
315L2-4	200	270	1485	96.0	0.89	359	341	328	1286	3	3	7.6
355M-4	250	340	1490	96.0	0.90	443	421	406	1602	2.8	2.9	7.5
355L-4	315	430	1490	96.0	0.90	559	531	511	2019	2.6	2.8	7.4

TECHNICAL DATA 技术参数

IE3&YE3

Type 型号	Rated Output 功率		Rated Speed 转速 (r/min)	Eff 效率 (%)	Power Factor 功率因数 (cosφ)	Current 电流 (A)			Rated Torque 额定转矩 (r/min)	堵转转矩 额定转矩 T _{st} /T _n	最大转矩 额定转矩 T _{max} /T _n	堵转电流 额定电流 I _{st} /I _n
	Kw	Hp				380V 50Hz	400V 50Hz	415V 50Hz				
90S-6	0.75	1	934	78.9	0.72	2.08	1.98	1.9	7.67	2.2	2.4	4.5
90L-6	1.1	1.5	945	81.0	0.72	2.97	2.82	2.72	11.1	2.4	2.6	4.5
100L-6	1.5	2	945	82.5	0.75	3.8	3.61	3.48	15.2	1.8	2.2	4.2
112M-6	2.2	3	960	84.3	0.76	5.37	5.1	4.92	21.9	2.3	2.8	4.5
132S-6	3	4	964	85.6	0.76	7.19	6.83	6.58	29.7	1.8	2.4	4.5
132M1-6	4	5.5	965	86.6	0.76	9.43	8.96	8.63	39.6	2.3	2.7	5
132M2-6	5.5	7.5	965	88.0	0.77	12.6	12	11.5	54.4	1.9	2.8	5.5
160M-6	7.5	10	970	89.1	0.78	16.7	15.9	15.3	73.8	2	3	6.5
160L-6	11	15	970	90.3	0.78	24.1	22.9	22.1	108.3	2.4	3.3	7.5
180L-6	15	20	975	91.2	0.81	31.4	29.8	28.7	146.9	2	2.7	6.4
200L1-6	18.5	25	980	91.7	0.81	38.3	36.4	35.1	180.3	2.3	3	7
200L2-6	22	30	980	92.2	0.83	44.3	42	40.5	214.4	2.3	2.8	7
225M-6	30	40	980	92.9	0.84	59.2	56.2	54.2	292.3	2.2	2.7	6.5
250M-6	37	50	980	93.3	0.86	70.8	67.3	64.8	360.6	2.5	2.7	6.9
280S-6	45	60	980	93.7	0.86	85.8	81.5	78.5	438.5	2.2	2.4	7
280M-6	55	75	980	94.1	0.86	104	99.2	95.6	536	2.4	2.5	7.1
315S-6	75	100	985	94.6	0.86	141	134	129	727.2	2.8	3	7.3
315M-6	90	125	985	94.9	0.86	169	160	155	872.6	2.7	2.9	7.1
315L1-6	110	150	985	95.1	0.86	206	196	189	1066	2.9	2.9	7.4
315L2-6	132	180	985	95.4	0.87	243	231	223	1280	3	3.1	7.6
355M1-6	160	200	990	95.6	0.88	291	277	267	1543	3.1	3.1	7.6
355M2-6	200	270	990	95.8	0.88	363	345	333	1929	3	3	7.8
355L-6	250	340	990	95.8	0.88	454	432	416	2412	3.1	3	7.7

三相异步电动机

INSTALLATION SIZE

安装尺寸 (mm)

IM B35 H80-355

80~132

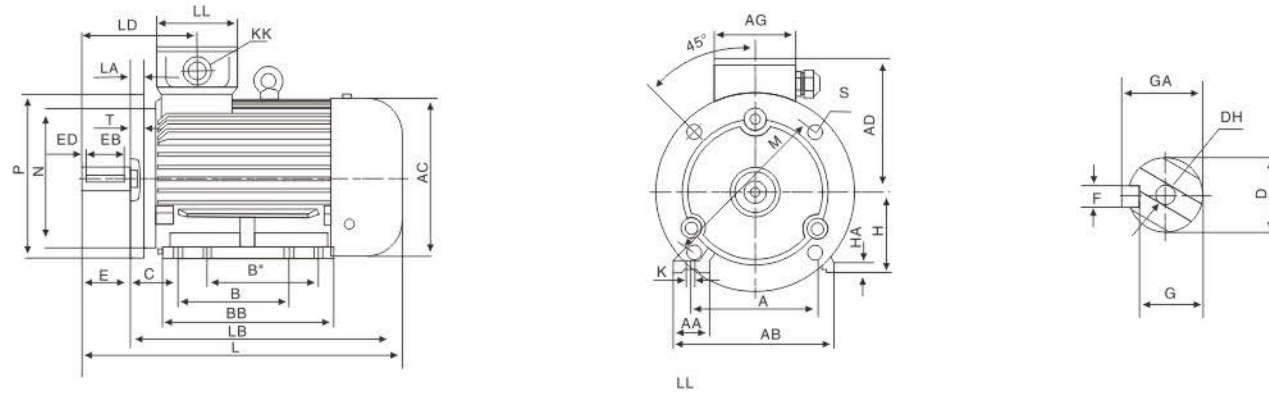

160~200

225~355

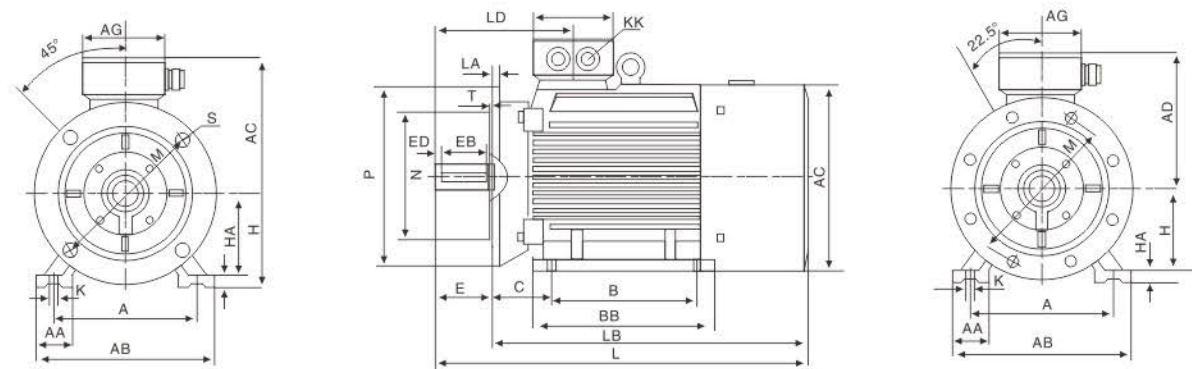

Type 型号	Poles 极数	A	AA	AB	AC	AD	AG	B	BB	C	D	DH	E	EB	ED	F	G	GA	H	HA	K	KK	L	LA	LB	LD	LL	M	N	P	S	T
80	2,4,6,8	125	34	160	167	147	102	100	150	50	19	M6x16	40	30	5	6	15.5	21.5	80	10	4-φ10	1-M25x1.5	304	12	264	112	102	165	130	200	12	3.5
90S	2,4,6,8	140	36	176	182.4	154.5	102	100	161	56	24	M8x19	50	40	5	8	20	27	90	12	4-φ10	1-M25x1.5	336	12	286	130	102	165	130	200	12	3.5
90L	2,4,6,8	140	36	176	182.4	154.5	102	125	186	56	24	M8x19	50	40	5	8	20	27	90	12	4-φ10	1-M25x1.5	361	12	311	130	102	165	130	200	12	3.5
100L	2,4,6,8	160	40	200	205.4	166	102	140	213	63	28	M10x22	60	50	5	8	24	31	100	14	4-φ12	1-M32x1.5	406	13	346	139	102	215	180	250	14.5	4
112M	2,4,6,8	190	50	240	219.4	182	118	140	225	70	28	M10x22	60	50	5	8	24	31	112	15	4-φ12	2-M32x1.5	452	14	392	147	110	215	180	250	14.5	4
132S	2,4,6,8	216	55	262	258.4	203	118	140	200	89	38	M12x28	80	65	7.5	10	33	41	132	18	4-φ12	2-M32x1.5	470	14	390	172	110	265	230	300	14.5	4
132M	4,6,8	216	55	262	258.4	203	118	178	238	89	38	M12x28	80	65	7.5	10	33	41	132	18	4-φ12	2-M32x1.5	508	14	428	172	110	265	230	300	14.5	4
160M	2,4,6,8	254	65	314	314	251	162	210	260	108	42	M16x36	110	90	10	12	37	45	160	20	4-φ14.5	2-M40x1.5	608	15	498	256	152	300	250	350	18.5	5
160L	2,4,6,8	254	65	314	314	251	162	254	304	108	42	M16x36	110	90	10	12	37	45	160	20	4-φ14.5	2-M40x1.5	652	15	542	258	152	300	250	350	18.5	5
180M	2,4,8	279	70	349	355	267	162	241	311	121	48	M16x36	110	90	10	14	42.5	51.5	180	22	4-φ14.5	2-M40x1.5	688	15	578	271	152	300	250	350	18.5	5
180L	4,6,8	279	70	349	355	267	162	279	349	121	48	M16x36	110	90	10	14	42.5	51.5	180	22	4-φ14.5	2-M40x1.5	726	15	616	271	152	300	250	350	18.5	5
200L	2,4,6,8	318	70	388	397	299	210	305	369	133	55	M20x42	110	100	5	16	49	59	200	25	4-φ16.5	2-M50x1.5	779	17	669	296	190	350	30	400	18.5	5
225S	4,8	356	75	431	446	322	210	286	368	149	60	M20x42	140	125	7.5	18	53	64	225	28	4-18.5	2-M50x1.5	824	20	684	329	190	400	350	450	18.5	5
225M	2	356	75	431	446	322	210	311	393	149	55	M20x42	110	100	5	16	49	59	225	28	4-φ18.5	2-M50x1.5	819	20	709	298	190	400	350	450	18.5	5
225M	4,6,8	356	75	431	446	322	210	311	393	149	60	M20x42	140	125	7.5	18	53	64	225	28	4-φ18.5	2-M50x1.5	849	20	709	329	190	400	350	450	18.5	5
250M	2	406	80	484	485	358	248	349	445	168	60	M20x42	140	125	7.5	18	53	64	250	30	4-φ24	2-M63x1.5	910	22	770	347	218	500	450	550	18.5	5
250M	4,6,8	406	80	484	485	358	248	349	445	168	65	M20x42	140	125	7.5	18	58	69	250	30	4-φ24	2-M63x1.5	910	22	770	347	218	500	450	550	18.5	5
280S	2	457	85	542	547	387	248	368	485	190	65	M20x42	140	125	7.5	18	58	69	280	35	4-φ24	2-M63x1.5	982	22	842	355.5	218	500	450	550	18.5	5
280S	4,6,8	457	85	542	547	387	248	368	485	190	75	M20x42	140	125	7.5	20	67.5	79.5	280	35	4-φ24	2-M63x1.5	982	22	842	355.5	218	500	450	550	18.5	5
280M	2	457	85	542	547	387	248	419	536	190	65	M20x42	140	125	7.5	18	58	69	280	35	4-φ24	2-M63x1.5	1033	22	893	355.5	218	500	450	550	18.5	5
280M	4,6,8	457	85	542	547	387	248	419	536	190	75	M20x42	140	125	7.5	20	67.5	79.5	280	35	4-φ24	2-M63x1.5	1033	22	893	355.5	218	500	450	550	18.5	5
315S	2	508	120	628	620	527	320	406	570	216	65	M20x42	140	125	7.5	18	58	69	315	45	4-28	2-M63x1.5	1194	22	1054	397	280	600	550	660	24	6
315S	4,6,8,10	508	120	628	620	527	320	406	570	216	80	M20x42	170	160	5	22	71	85	315	45	4-φ28	2-M63x1.5	1224	22	1054	427	280	600	550	660	24	6
315M	2	508	120	628	620	527	320	457	680	216	65	M20x42	140	125	7.5	18	58	69	315	45	4-φ28	2-M63x1.5	1304	22	1164	397	280	600	550	660	24	6
315M	4,6,8,10	508	120	628	620	527	320	457	680	216	80	M20x42	170	160	5	22	71	85	315	45	4-φ28	2-M63x1.5	1334	22	1164	427	280	600	550	660	24	6
315L	2	508	120	628	620	527	320	508	680	216	65	M20x42	140	125	7.5	18	58	69	315	45	4-φ28	2-M63x1.5	1304	22	1184	397	280	600	550	660	24	6
315L	4,6,8,10	508	120	628	620	527	320	508	680	216	80	M20x42	170	160	5	22	71	85	315	45	4-φ28	2-M63x1.5	1334	22	1164	427	280	600	550	660	24	6
355M	2	610	116	726	698	642	380	560	750	254	75	M20x50	140	130	5	20	67.5	79.5	355	52	6-φ28	2-M63x1.5	1486	25	1346	414	330	740	680	800	24	6
355M	4,6,8,10	610	116	726	698	642	380	560	750	254	95	M24x50	170	160	5	25	86	100	355	52	6-φ28	2-M63x1.5	1516	25	1346	444	330	740	680	800	24	6
355L	2	610	116	726	698	642	380	630	750	254	75	M20x50	140	130	5	20	67.5	79.5	355	52	6-φ28	2-M63x1.5	1486	25	1346	414	330	740	680	800	24	6
355L	4,6,8,10	610	116	726	698	642	380	630	750	254	95	M24x50	170	160	5	25	86	100	355	52	6-2φ8	2-M63x1.5	1516	25	1346	444	330	740	680	800	24	6

三相异步电动机

IE2&YE2 Three-phase Electrical motors 三相异步电动机

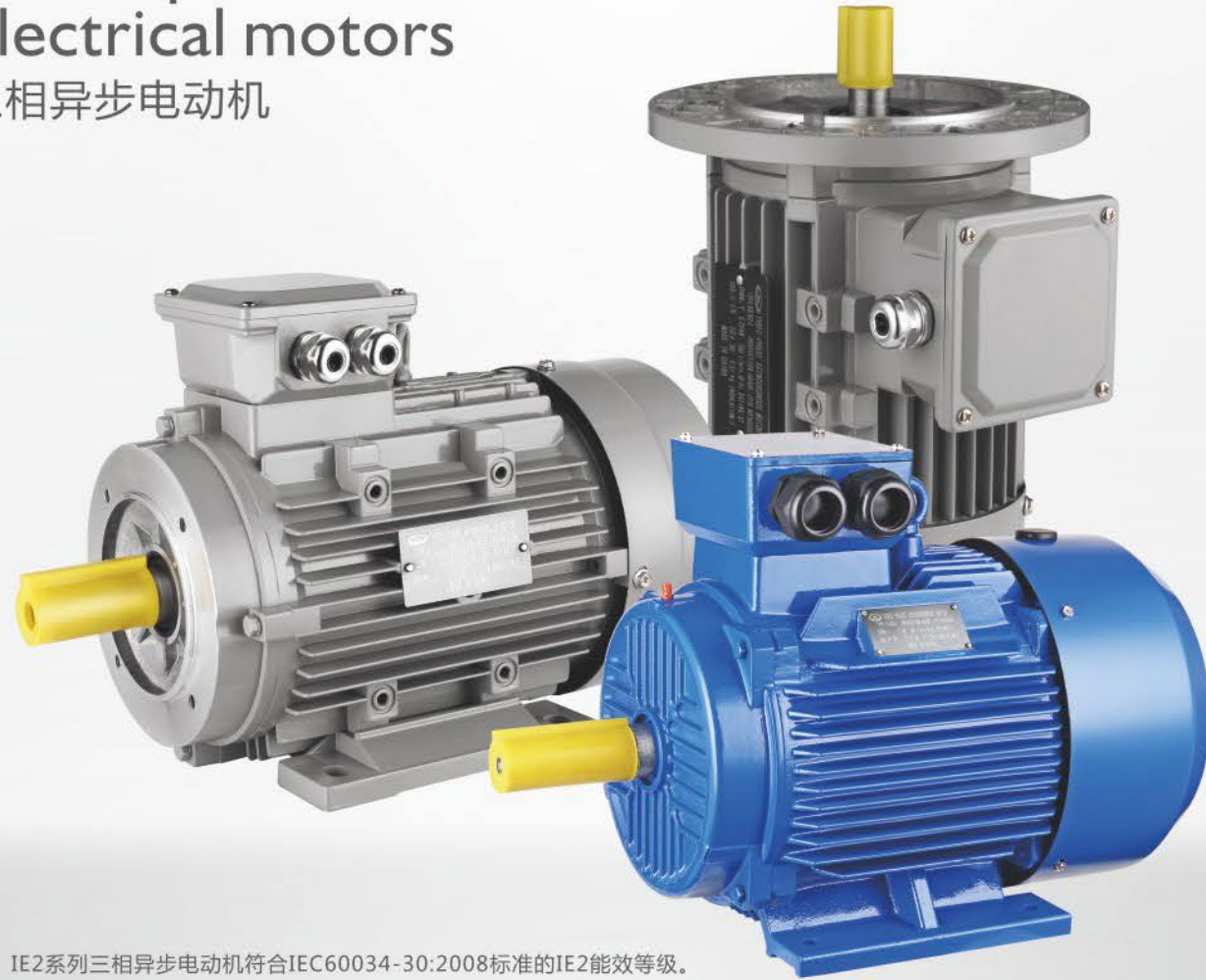

IE2系列三相异步电动机符合IEC60034-30:2008标准的IE2能效等级。

IE2系列三相异步电动机的安装尺寸符合IEC60034标准，具有结构合理，外表美观、噪声低、防护等级高、绝缘等级高等优点，可广泛应用于风机、水泵、机床、压缩机、运输机械等各种通用机械设备，也可在石油、化工、钢铁、矿山等其他环境比较恶劣的场所使用。

IE2 series three-phase asynchronous motors meet IEC60034-30:2008 standard IE2 energy efficiency level.

IE2 series three-phase asynchronous motors are installed in accordance with IEC60034 standard. They have the advantages of reasonable structure, beautiful appearance, low noise, high protection level and high insulation level. They can be widely used in fans, pumps, machine tools, compressors, transport machinery and other general mechanical equipment. They can also be used in petroleum, chemical, iron and steel, mines and other places where the environment is harsh.

TECHNICAL DATA 技术参数

IE2&YE2

Type 型号	Rated Output 功率		Rated Speed 转速 (r/min)	Eff 效率 (%)	Power Factor 功率因数 (cosφ)	Current 电流 (A)			Rated Torque 额定转矩 (r/min)	堵转转矩 额定转矩 T _{st} /T _n	最大转矩 额定转矩 T _{max} /T _n	堵转电流 额定电流 I _{st} /I _n
	Kw	Hp				380V 50Hz	400V 50Hz	415V 50Hz				
801-2	0.75	1	2875	77.4	0.83	1.77	1.68	1.62	2.49	2.5	3	5.3
802-2	1.1	1.5	2875	79.6	0.84	2.50	2.37	2.29	3.65	3.2	3.8	7
90S-2	1.5	2	2890	81.3	0.84	3.32	3.16	3.04	4.96	2.7	3.5	7.1
90L-2	2.2	3	2890	83.2	0.85	4.72	4.48	4.32	7.27	2.4	3	6.9
100L-2	3	4	2891	84.6	0.87	6.17	5.86	5.65	9.91	3.2	4	8.0
112M-2	4	5.5	2914	85.8	0.88	8.04	7.64	7.36	13.11	2.5	3	7.5
132S1-2	5.5	7.5	2937	87.0	0.86	11.2	10.6	10.2	17.88	2.7	3.5	7.5
132S2-2	7.5	10	2940	88.1	0.88	14.6	13.9	13.4	24.36	2.4	3.3	7.5
160M1-2	11	15	2930	89.4	0.89	21.0	19.9	19.2	35.85	2.2	2.9	7.6
160M2-2	15	20	2930	90.3	0.89	28.4	26.9	26.0	48.89	2.3	3	7.6
160L-2	18.5	25	2937	90.9	0.89	34.7	33.0	31.8	60.15	2.3	3.1	7.4
180M-2	22	30	2940	91.3	0.88	41.6	39.5	38.1	71.12	2.8	3.2	7.8
200L1-2	30	40	2950	92.0	0.88	56.2	53.4	51.5	97.12	2.6	3	7.8
200L2-2	37	50	2950	92.5	0.89	68.2	64.8	62.5	119.78	2.6	3	7.7
225M-2	45	60	2960	92.9	0.89	82.5	78.4	75.6	145.19	2.4	2.6	7.5
250M-2	55	75	2965	93.2	0.90	99.5	94.5	91.1	177.15	2.3	2.8	7.1
280S-2	75	100	2970	93.8	0.90	135	128	123	241.16	2.5	2.8	7.4
280M-2	90	125	2970	94.1	0.91	160	152	146	289.39	2.8	2.8	7.6
315S-2	110	150	2975	94.3	0.91	194	185	178	353.11	2.4	2.8	6.9
315M-2	132	180	2975	94.6	0.91	233	221	213	423.73	2.6	2.9	7.1
315L1-2	160	200	2975	94.8	0.92	278	265	255	513.61	2.5	2.9	7.1
315L2-2	200	270	2975	95.0	0.92	348	330	318	642.02	2.5	2.8	6.9
355M-2	250	340	2980	95.0	0.92	434	412	398	801.17	2.5	2.8	7
355L-2	315	430	2980	95.0	0.92	547	520	501	1009.48	2.5	2.9	7

三相异步电动机

TECHNICAL DATA 技术参数

IE2&YE2

Type 型号	Rated Output 功率		Rated Speed 转速 (r/min)	Eff 效率 (%)	Power Factor 功率因数 (cosφ)	Current 电流 (A)			Rated Torque 额定转矩 (r/min)	堵转转矩 额定转矩 T _{st} /T _n	最大转矩 额定转矩 T _{max} /T _n	堵转电流 额定电流 I _{st} /I _n
	Kw	Hp				380V 50Hz	400V 50Hz	415V 50Hz				
802-4	0.75	1	1400	79.6	0.76	1.88	1.78	1.72	5.12	2.4	2.9	5
90S-4	1.1	1.5	1440	81.4	0.77	2.66	2.53	2.44	7.3	3	3.5	6
90L-4	1.5	2	1445	82.8	0.77	3.57	33.9	3.27	9.91	3.2	3.8	6.8
100L1-4	2.2	3	1440	84.3	0.81	4.88	4.64	4.47	14.6	3	3.5	7
100L2-4	3	4	1440	85.5	0.82	6.50	6.18	5.95	19.9	2.6	3.3	7
112M-4	4	5.5	1445	86.6	0.82	8.55	8.12	7.83	26.4	3.5	4	7.5
132S-4	5.5	7.5	1455	87.7	0.83	11.5	10.9	10.5	36.1	2.2	2.8	6.4
132M-4	7.5	10	1455	88.7	0.84	15.3	14.5	14.0	49.2	2.4	3	7
160M-4	11	15	1460	89.8	0.84	22.1	21.0	20.3	71.9	2.5	2.9	6.9
160L-4	15	20	1460	90.6	0.85	29.6	28.1	27.1	98.1	2.5	3	7.5
180M-4	18.5	25	1470	91.2	0.86	35.8	34.0	32.8	120.2	2.6	3.1	7.8
180L-4	18.5	25	1470	91.2	0.86	35.8	34.0	32.8	120.2	2.6	3.1	7.8
200L-4	30	40	1470	92.3	0.86	57.3	54.4	52.5	194.9	2.4	2.9	7.1
225S-4	37	50	1480	92.7	0.87	69.7	66.2	63.8	238.8	2.5	2.7	7.5
225M-4	45	60	1480	93.1	0.87	84.3	80.1	77.2	290.4	2.5	2.8	7.6
250M-4	55	75	1480	93.5	0.87	103	97.5	94.0	354.9	2.6	2.7	7.3
280S-4	75	100	1480	94.0	0.87	139	132	127	484	2.7	2.7	7.6
280M-4	90	125	1480	94.2	0.87	167	158	153	580.7	2.7	2.7	7.5
315S-4	110	150	1485	94.5	0.88	201	191	184	707.4	2.7	2.9	7.1
315M-4	132	180	1485	94.7	0.88	240	228	220	848.9	2.7	2.9	7.3
315L1-4	160	200	1485	94.9	0.89	288	273	263	1029	3	3	7.4
315L2-4	200	270	1485	95.1	0.89	359	341	328	1286	3	3	7.6
355M-4	250	340	1490	95.1	0.90	443	421	406	1602	2.8	2.9	7.5
355L-4	315	430	1490	95.1	0.90	559	531	511	2019	2.6	2.8	7.4

TECHNICAL DATA 技术参数

IE2&YE2

Type 型号	Rated Output 功率		Rated Speed 转速 (r/min)	Eff 效率 (%)	Power Factor 功率因数 (cosφ)	Current 电流 (A)			Rated Torque 额定转矩 (r/min)	堵转转矩 额定转矩 T _{st} /T _n	最大转矩 额定转矩 T _{max} /T _n	堵转电流 额定电流 I _{st} /I _n
	Kw	Hp				380V 50Hz	400V 50Hz	415V 50Hz				
90S-6	0.75	1	934	75.9	0.72	2.08	1.98	1.9	7.67	2.2	2.4	4.5
90L-6	1.1	1.5	945	78.1	0.72	2.97	2.82	2.72	11.1	2.4	2.6	4.5
100L-6	1.5	2	945	79.8	0.75	3.8	3.61	3.48	15.2	1.8	2.2	4.2
112M-6	2.2	3	960	81.8	0.76	5.37	5.1	4.92	21.9	2.3	2.8	4.5
132S-6	3	4	964	83.3	0.76	7.19	6.83	6.58	29.7	1.8	2.4	4.5
132M1-6	4	5.5	965	84.6	0.76	9.43	8.96	8.63	39.6	2.3	2.7	5
132M2-6	5.5	7.5	965	86	0.77	12.6	12	11.5	54.4	1.9	2.8	5.5
160M-6	7.5	10	970	87.2	0.78	16.7	15.9	15.3	73.8	2	3	6.5
160L-6	11	15	970	88.7	0.78	24.1	22.9	22.1	108.3	2.4	3.3	7.5
180L-6	15	20	975	89.7	0.81	31.4	29.8	28.7	146.9	2	2.7	6.4
200L1-6	18.5	25	980	90.4	0.81	38.3	36.4	35.1	180.3	2.3	3	7
200L2-6	22	30	980	90.9	0.83	44.3	42	40.5	214.4	2.3	2.8	7
225M-6	30	40	980	91.7	0.84	59.2	56.2	54.2	292.3	2.2	2.7	6.5
250M-6	37	50	980	92.2	0.86	70.8	67.3	64.8	360.6	2.5	2.7	6.9
280S-6	45	60	980	92.7	0.86	85.8	81.5	78.5	438.5	2.2	2.4	7
280M-6	55	75	980	93.1	0.86	104	99.2	95.6	536	2.4	2.5	7.1
315S-6	75	100	985	93.7	0.86	141	134	129	727.2	2.8	3	7.3
315M-6	90	125	985	94	0.86	169	160	155	872.6	2.7	2.9	7.1
315L1-6	110	150	985	94.3	0.86	206	196	189	1066	2.9	2.9	7.4
315L2-6	132	180	985	94.6	0.87	243	231	223	1280	3	3.1	7.6
355M1-6	160	200	990	94.8	0.88	291	277	267	1543	3.1	3.1	7.6
355M2-6	200	270	990	95	0.88	363	345	333	1929	3	3	7.8
355L-6	250	340	990	95	0.88	454	432	416	2412	3.1	3	7.7

IE1

Three-phase Electrical motors

三相异步电动机

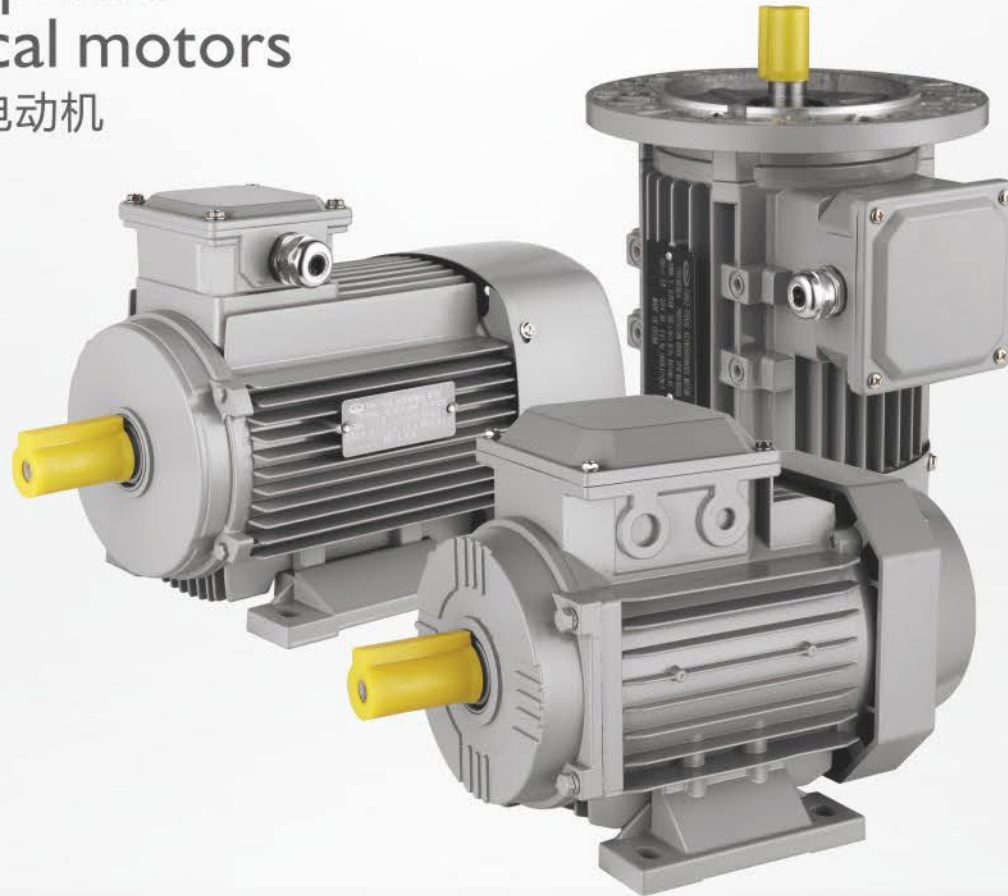

Details

Ambient condition

IE1 series could be applied on most occasions and ambients. The standard working condition is -20°C-40°C, not exceeding 1000M attitudes.

Temperature rise and Insulation

The motor is designed according to F level insulation(155°C) and examined according to B level insulation(80K) to ensure the service life and dependability.

Cooling and ventilation

The standard cooling method is enclosed fan-cooled(TEFC). The standard motor has Auxiliary flow plastic fan which meets the stipulation of IC411 in IEC 60034-6.

Level of protection

The protection level of electrical motors is IP55 which can work in dust or damp ambients. Higher motor protection level is available according to customer requirements.

Motor protection

PTC/PT100 etc.winding, bearing temperature measurement and protector could be installed according to customer requirements.

Rated voltage and frequency

The standard working voltage and frequency for an electrical motor is 380V/50HZ. The working voltage could be customized according to customer request from 200-660V with 50Hz working frequency. The motor can still work normally when there is ±5% voltage deviation.

Vibration

The vibration speed of Y2 series electrical motor accord with A grade when it is no-load. B grade motor is available when there are special requirements.

Terminal box location

The terminal box is located on the upside or the right side of the motor.

Quality Assurance

From product design to product export, we strictly follow the ISO9001 quality certification system and quality procedure.

PRODUCT OVERVIEW 产品概述

IE1系列三相异步电动机符合IEC60034-30:2008标准的IE1能效等级。

IE1系列三相异步电动机的安装尺寸符合IEC60034标准，具有结构合理，外表美观、噪声低、防护等级高、绝缘等级高等优点，可广泛应用于风机、水泵、机床、压缩机、运输机械等各种通用机械设备，也可在石油、化工、钢铁、矿山等其他环境比较恶劣的场所使用。

IE1 series three-phase electrical motors meet IEC60034-30:2008 standard IE1 energy efficiency level.

IE1 series three-phase asynchronous motors are installed in accordance with IEC60034 standard. They have the advantages of reasonable structure, beautiful appearance, low noise, high protection level and high insulation level. They can be widely used in fans, pumps, machine tools, compressors, transport machinery and other general mechanical equipment. They can also be used in petroleum, chemical, iron and steel, mines and other places where the environment is harsh.

DESIGNATION 型号说明

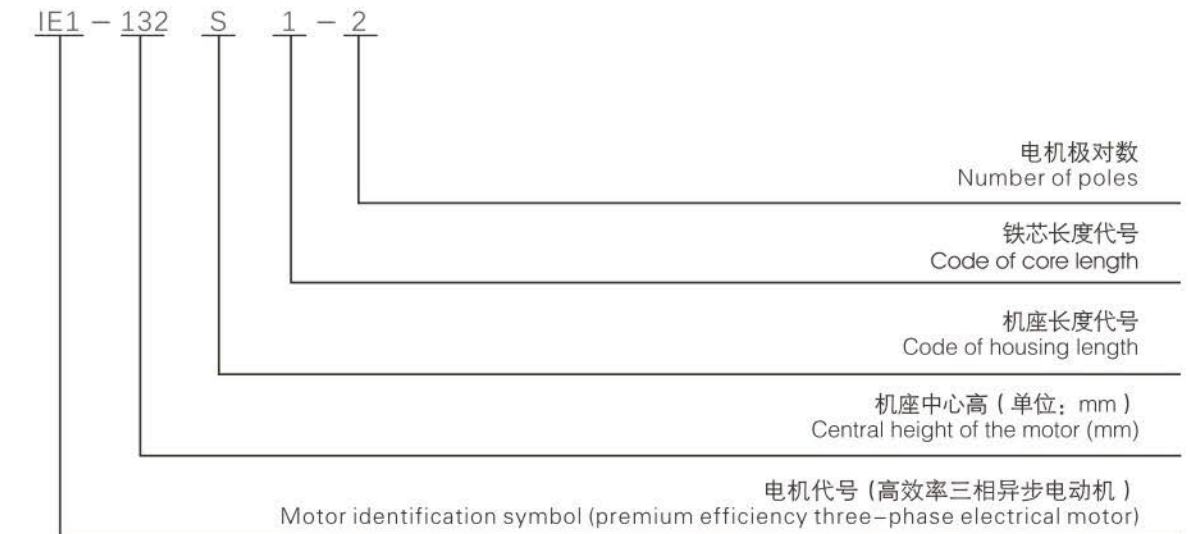

详细说明 Details

现场条件

IE1系列电动机可适用于大多数的场合及环境。电动机标准工作条件为-20°C到+40°C，海拔1000米。

温升和绝缘

电动机按F级绝缘设计(155°C)，按B级绝缘考核(80K)，电动机的使用寿命和可靠性得到保证。

冷却和通风

标准冷却方式为全封闭自扇冷(TEFC)。标准电机装有辅助式塑料风扇。符合IEC 60034-6和IC411的规定。

防护等级

电动机的防护等级为IP55,可用于含尘或潮湿环境。也可根据客户要求提供更高防护等级的电动机。

电机保护

可根据要求安装RTC、PT100等绕组和轴承测温及保护装置。

电压、频率

标准电机为380V/50HZ。可设计200-660V范围内任意电压的50Hz的电动机。在供电电压偏离额定电压±5%的情况下，仍能良好运行。

振动

IE1系列电动机在空载时振动速度等级符合A级。特殊要求时，可提供B级电动机。

接线盒位置

接线盒在机座上方或右侧为标准YE2系列电机。

质量保证

从产品设计到产品出厂，遵循ISO9001质量认证体系，严格遵守质量程序。

三相异步电动机

额定电压 : 380V 频率 : 50Hz Rated Voltage:380V Frequency:50Hz

Type 型号	Rated Output 功率		Speed 转速 (r/min)	Current 电流 (A)	Eff 效率 (%)	P.F. 功率因素 cosφ	堵转电流 额定电流 Ist/In	堵转转矩 额定转矩 Tst/Tn	最大转矩 额定转矩 Tmax/Tn
	Kw	Hp							
同步转速 Synchronous Speed 3000/rpm									
631-2	0.18	1/4	2720	0.53	65	0.8	5.5		2.2
632-2	0.25	1/3	2720	0.69	68	0.81			
711-2	0.37	1/2	2740	0.69	70	0.81	6.1		
712-2	0.55	3/4	2740	1.4	73	0.82			
801-2	0.75	1	2830	1.83	75	0.83	7	2.2	
802-2	1.1	1.5	2830	2.58	76.2	0.84			
90S-2	1.5	2	2840	3.43	78.5	0.85			
90L-2	2.2	3	2840	4.85	81				
100L-2	3	4	2870	6.31	82.6	0.87	7.5	2.3	
112M-2	4	5.5	2890	8.1	84.2	0.88			
132S1-2	5.5	7.5	2900	11	85.7		0.89		
132S2-2	7.5	10	2900	14.9	87				
160M1-2	11	15	2930	21.3	88.4	0.9			
160M2-2	15	20	2930	28.8	89.4				
160L-2	18.5	25	2930	34.7	90	0.91	7.1	1.8	2.2
180M-2	22	30	2940	41	90.5				
200L1-2	30	40	2950	55.5	91.4	0.92			
200L2-2	37	50	2950	67.9	92				
225M-2	45	60	2970	82.3	92.5	0.93	2		
250M-2	55	75	2970	101	93				
280S-2	75	100	2970	134	93.6	0.94			
280M-2	90	125	2970	160	93.9				
315S-2	110	150	2980	195	94	0.95			
315M-2	132	180	2980	233	94.5				
315L1-2	160	220	2980	279	94.6	0.96			
315L2-2	200	270	2980	348	94.8				

额定电压 : 380V 频率 : 50Hz Rated Voltage:380V Frequency:50Hz

Type 型号	Rated Output 功率		Speed 转速 (r/min)	Current 电流 (A)	Eff 效率 (%)	P.F. 功率因素 cosφ	堵转电流 额定电流 Ist/In	堵转转矩 额定转矩 Tst/Tn	最大转矩 额定转矩 Tmax/Tn
	Kw	Hp							
同步转速 Synchronous Speed 1500/rpm									
631-4	0.12	1/6	1310	0.44	57	0.72	4.4		
632-4	0.18	1/4		0.62	60	0.73			
711-4	0.25	1/3	1330	0.79	65	0.74	5.2	2.1	2.2
712-4	0.37	1/2		1.12	67	0.75			
801-4	0.55	3/4	1390	1.57	71	0.76	6		
802-4	0.75	1		2.03	73				
90S-4	1.1	1.5	1400	2.89	76.2	0.77			
90L-4	1.5	2		3.7	78.5				
100L1-4	2.2	3	1430	5.16	81	0.81	7	2.3	
100L2-4	3	4		6.78	82.6				
112M-4	4	5.5	1440	8.8	84.2	0.83			
132S-4	5.5	7.5		11.7	85.7				
132M-4	7.5	10	1460	15.6	87	0.84			
160M-4	11	15		22.3	88.4				
160L-4	15	20	1470	30.1	89.4	0.85	7.5		
180M-4	18.5	25		36.5	90				
180L-4	22	30	1480	43.2	90.5	0.86			
200L-4	30	40		57.6	91.4				
225S-4	37	50	1480	69.9	92	0.87	7.2		
225M-4	45	60		84.7	92.5				
250M-4	55	75	1490	103	93	0.88			
280S-4	75	100		140	93.6				
280M-4	90	125	1490	167	93.9	0.89	6.9	2.1	2.2
315S-4	110	150		201	94.5				
315M-4	132	180	1490	240	94.8	0.89			
315L1-4	160	220		287	94.9				
315L2-4	200	270		359	94.9				

三相异步电动机

额定电压 : 380V 频率 : 50Hz Rated Voltage:380V Frequency:50Hz

Type 型号	Rated Output 功率		Speed 转速 (r/min)	Current 电流 (A)	Eff 效率 (%)	P.F. 功率因素 cosφ	堵转电流 额定电流 Ist/In	堵转转矩 额定转矩 Tst/Tn	最大转矩 额定转矩 Tmax/Tn
	Kw	Hp							
同步转速 Synchronous Speed 1000/rpm									
711-6	0.18	1/4	850	0.74	56	0.66	4	1.9	2
712-6	0.25	1/3		0.95	59	0.66			
801-6	0.37	1/2	890	1.3	62	0.7	4.7	1.9	2
802-6	0.55	3/4		1.79	65	0.72			
90S-6	0.75	1	910	2.29	69	0.73	5.5	2	2.1
90L-6	1.1	1.5		3.18	72				
100L-6	1.5	2	940	3.94	76	0.75	6.5	2.1	2.1
112M-6	2.2	3		5.6	79	0.76			
132S-6	3	4	960	7.4	81	0.77	7	2.1	2.1
132M1-6	4	5.5		9.8	82				
132M2-6	5.5	7.5	970	12.9	84	0.78	7	2.1	2.1
160M-6	7.5	10		17	86				
160L-6	11	15	970	24.2	87.5	0.81	7	2.1	2.1
180L-6	15	20		31.6	89				
200L1-6	18.5	25	980	38.6	90	0.83	7	2.1	2.1
200L2-6	22	30		44.7	90				
225M-6	30	40	980	59.3	91.5	0.84	7	2.1	2.1
250M-6	37	50		71	92				
280S-6	45	60	990	86	92.5	0.86	7	2.1	2.1
280M-6	55	75		105	92.8				
315S-6	75	100	990	141	93.5	0.86	7	2.1	2.1
315M-6	90	125		169	93.8				
315L1-6	110	150	990	206	94	0.86	7	2.1	2.1
315L2-6	132	180		244	94.2				

额定电压 : 380V 频率 : 50Hz Rated Voltage:380V Frequency:50Hz

Type 型号	Rated Output 功率		Speed 转速 (r/min)	Current 电流 (A)	Eff 效率 (%)	P.F. 功率因素 cosφ	堵转电流 额定电流 Ist/In	堵转转矩 额定转矩 Tst/Tn	最大转矩 额定转矩 Tmax/Tn
	Kw	Hp							
同步转速 Synchronous Speed 750/rpm									
801-8	0.18	1/4	630	0.88	51	0.61	3.3	1.9	1.9
802-8	0.25	1/3	640	1.15	54				
90S-8	0.37	1/2	660	1.49	62	0.67	4	1.8	1.9
90L-8	0.55	3/4		2.18	63				
100L1-8	0.75	1	690	2.17	71	0.69	5	1.8	1.9
100L2-8	1.1	1.5		2.39	73				
112M-8	1.5	2	680	4.5	75	0.71	5	1.8	1.9
132S-8	2.2	3		6	78				
132M-8	3	4	710	7.9	79	0.73	6	1.9	1.9
160M1-8	4	5.5		10.3	81				
160M2-8	5.5	7.5	720	13.6	83	0.74	6	1.9	1.9
160L-8	7.5	10		17.8	85.5				
180L-8	11	15	730	25.1	87.5	0.76	6	1.9	1.9
200L-8	15	20		34.1	88				
225S-8	18.5	25	740	40.6	90	0.78	6.6	1.9	1.9
225M-8	22	30		47.4	90.5				
250M-8	30	40	740	64	91	0.79	6.6	1.9	1.9
280S-8	37	50		78	91.5				
280M-8	45	60	740	94	92	0.81	6.6	1.9	1.9
315S-8	55	75		111	92.8				
315M-8	75	100	740	151	93	0.82	6.4	1.8	1.8
315L1-8	90	125		178	93.8				
315L2-8	110	150	590	217	94	0.82	6.4	1.8	1.8
315S-10	45	60		100	91.5				
315M-10	55	75	590	121	92	0.75	6.2	1.5	2
315L1-10	75	100		162	92.5				
315L2-10	90	125	590	191	93	0.77	6.2	1.5	2

变频调速专用三相异步电动机

YVF2

Three-phase variable frequency and adjusting speed motor

变频调速专用三相异步电动机

YVF2系列变频调速专用三相异步电动机本系列电动机是变频调速专用三相异步电动机与电子变频器联合使用，可实现转速150~2750rpm(4极)范围内的无级调速，是那些有大范围无级调速需求的机械设备的理想动力。广泛应用于交通运输、冶金、纺织、印染、化工、矿山、风机、水泵等行业。其电气性能和安装尺寸按国家标准JB/T7118要求制造，并与国际IEC标准接轨。

YVF2 series three-phase asynchronous motor for variable frequency speed regulation is used in combination with electronic frequency converter for variable frequency speed regulation. This can achieve stepless speed regulation within the range of 150-2750rpm (4-pole) and is the ideal power for that mechanical equipment with large-scale stepless speed regulation requirements. Widely used in transportation, metallurgy, textile, printing and dyeing, chemical, mining, fans, pumps and other industries. Its electrical performance and installation dimensions are manufactured according to the national standard JB/T7118 and in line with the international IEC standard.

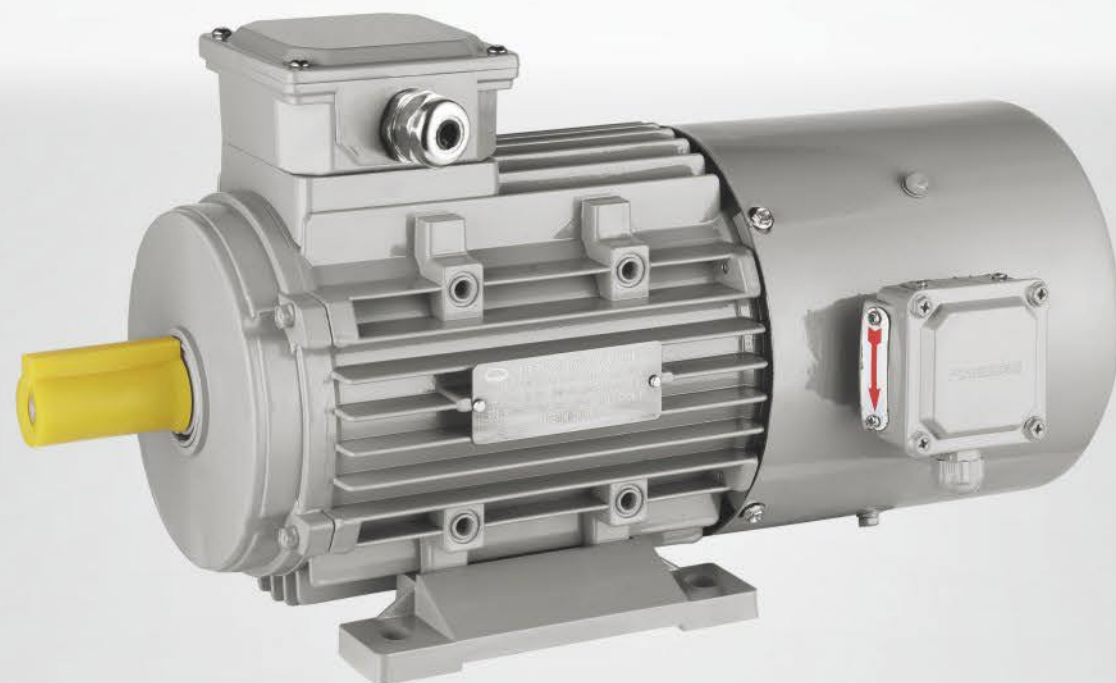

OPERATING CONDITIONS 使用条件

环境温度: -15°C ~ 40°C
 海拔: 不超过1000米
 额定电压: 380V、400V、415V
 额定频率: 50Hz
 接法: 额定功率55kW及以下电机为Y接法
 额定功率55kW以上电机为Δ接法
 工作制: 连续工作制(S1)
 防护等级: IP54 / IP55
 绝缘等级: B级 / F级
 冷却方式: IC416

Ambient Temperature: -15°C ~ 40°C
 Altitude: Up to 1000 meters
 Rated Voltage: 380V, 400V, 415V
 Rated Frequency: 50Hz
 Connection: Output ≤ 55kW, 'Y' connection
 Output > 55kW, 'Δ' connection
 Duty: Continuous (S1)
 Ingress Protection: IP54 / IP55
 Insulation Class: Class B / Class F
 Cooling Method: IC416

TECHNICAL DATA 技术参数

TYPE 型号	Rated Output 功率		Current 电流 (A)	Rated torque 额定转矩 (N.m)	Frequency at constant torque 恒转矩变频范围 (Hz)	Frequency at constant power 恒功率变频范围 (Hz)	堵转电流 额定电流 I _{st} /I _N	堵转转矩 额定转矩 T _{st} /T _N	最大转矩 额定转矩 T _{max} /T _N	最小转矩 额定转矩 T _{min} /T _N
	KW	Hp								
80M1-4	0.55	0.75	1.5	3.5	5-50	50-100	2	10	2.8	1.7
80M2-4	0.75	1	2	4.7	5-50	50-100	2	10	2.8	1.6
90S-4	1.1	1.5	2.8	7	5-50	50-100	2	10	2.8	1.6
90L-4	1.5	2	3.7	9.5	5-50	50-100	2	10	2.8	1.6
100L1-4	2.2	3	5.1	14	5-50	50-100	2	10	2.8	1.5
100L2-4	3	4	6.8	19	5-50	50-100	2	10	2.8	1.5
112M-4	4	5.5	8.7	25.4	5-50	50-100	2	10	2.8	1.5
132S-4	5.5	7.5	11.4	35	5-50	50-100	2	10	2.8	1.4
132M-4	7.5	10	15.3	47.7	5-50	50-100	2	10	2.8	1.4
160M-4	11	15	22.1	70	5-50	50-100	2	10	2.8	1.4
160L-4	15	20	30.1	95.5	5-50	50-100	2	10	2.8	1.4
180M-4	18.5	25	35.4	117.1	5-50	50-100	2	10	2.8	1.2
180L-4	22	30	41.6	140.9	5-50	50-100	2	10	2.8	1.2
200L-4	30	40	55.9	190.9	5-50	50-100	2	10	2.8	1.2
225S-4	37	50	68.2	235.5	5-50	50-100	2	10	2.8	1.2
225M-4	45	60	82.5	286.4	5-50	50-100	2	10	2.8	1.1
250M-4	55	75	101	350.1	5-50	50-100	1.7	10	2.8	1.1
280S-4	75	100	132.3	477.1	3-50	50-100	1.7	10	2.8	1
280M-4	90	125	157.4	572.9	3-50	50-100	1.7	10	2.8	1
315S-4	110	150	191.4	700.2	3-50	50-100	1.7	10	2.8	1
315M-4	132	180	227.6	840.3	3-50	50-100	1.7	10	2.8	1
315L1-4	160	220	274.2	1018.5	3-50	50-100	1.7	10	2.8	1
315L2-4	200	270	341.6	1273.2	3-50	50-100	1.7	10	2.8	0.9

电磁制动三相异步电动机

PRODUCT OVERVIEW 产品概述

YEJ2、YDEJ2系列电磁制动电动机是YEJ系列的改进产品，符合国家标准JB/T6456要求，电气性能满足Y2系列电机技术标准。YDEJ2是YEJ2系列的延伸产品。该系列制动电动机是在电机非拖动轴端装有电磁制动器，当电机失电时，电磁制动器的制动盘自动与电机后盖压合，产生摩擦制动力矩，使电机停转，空载制动时间随机座号由小到大，为0.15~0.45S。制动器电源必须拖动电机。电源同步进行。YEJ2、YDEJ2系列电机广泛应用于机械加工机床和输送机械及包装、木工、食品、化工、纺织、建筑、商店、卷门等机械作为驱动力。

YEJ2,YDEJ2 series electromagnetic brake motors are improved products of YEJ series. It is in accordance with JB/T6456 requirements, and its electrical performance is in accord with Y2 series technical standard. The electric power of the controller should be synchronized with the electric power of the motor.

The electric motors are equipped with the electromagnetic brake on the non-shaft end. When electricity off, the retarding disc will automatically press in endshield which produces friction brake torque and stops the running of motor, the no-load brake duration is changed with the frame size of the motor, the range is 0.15-0.45 seconds. This kind of motor is considered as the driving force of various machinery and widely used in mechanical workout machine tool, transport machinery, package, woodworking, food machinery chemical engineering, textile, construction, shop, roll door machinery.

TECHNICAL DATA 技术参数

机座中心高:63-225mm

控制器电源:机座中心高 $H \leq 100$ mm,
交流220V (整流后99V)

机座中心高: $H \geq 112$ mm, 交流380V
(整流后170V)

功率范围:0.12~45kW

额定电压:380V (其他电压需另订协议)

额定频率:50Hz (或60Hz)

防护等级:IP54 (或IP55)

绝缘等级:B/F级

工作制:S1

Centre height of frame:63-225mm

Controller's power:

centre height of frame: ≤ 100 mm, AC220V (after commutate99V)
centre height of frame: ≥ 112 mm, AC380V (after commutate170V)

Power range:0.12-45kW

Rated voltage:380V or order

Rated frequency:50Hz or 60Hz

Protection class: IP54 (or Ip55)

Insulation class:B/F Duty type:S1

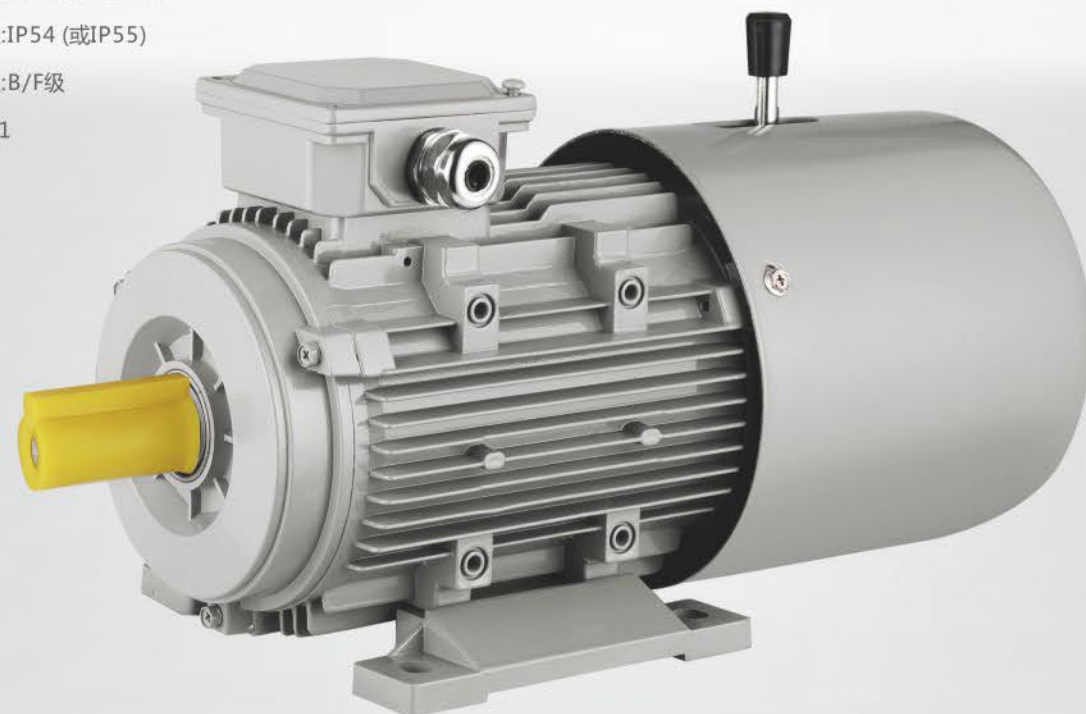

INSTALLATION SIZE 安装尺寸 (mm)

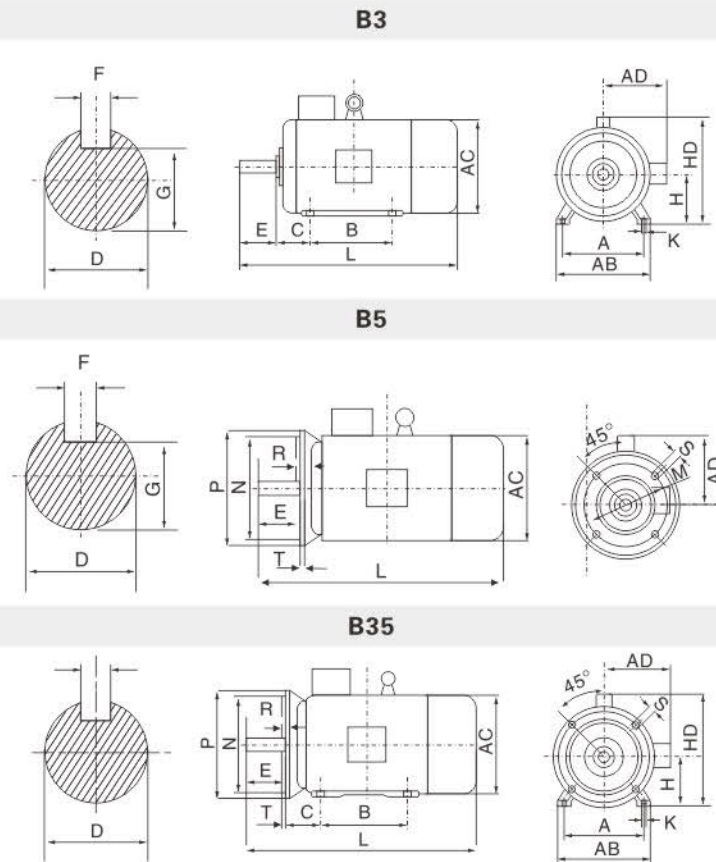

(B3-63-355 Frame with feet and endshield without flange / (B3) 机座有机脚，端盖没有凸缘

(B35-63-355)Frame with feet and endshield with flange(with plain holes) / (B35)机座有机脚，端盖有凸缘(凸缘带孔)

(5-63-255) Frame without feet and endshield with flange (with plain holes) / (B5) 机座没有机脚，端盖有凸缘(凸缘无孔)

Frame size 型号尺寸	Flange No 凸缘型号	Poles 极数	Mounting dimensions(mm) 安装尺寸 (mm)														Flange holes 凸缘孔	Overall dimensions(mm) 外形尺寸 (mm)											
			A	A/2	B	C	D	E	F	G	H	K	M	N	P	R		S	T	AB	AC	AD	HD	L					
80M		2,4	125	62.5		50	19	40	6	15.5	80													165	175	150	175	390	
90S	FF165		140	70	100	56	24	50		20	90	10	165	130	200		12	3.5						180	195	160	195	420	
90L		2,4,6			125				8																			445	
100L			160	80		63	28	60		24	100			215	180	250									205	315	180	245	480
112M	FF215		190	95	140	70					112														245	240	190	265	510
132S			216	108		89	38	80	10	33	132			265	230	300	0								280	275	210	315	585
132M	FF265				178																							625	
160M			254	127	210	108	42		12	37	160																	720	
160L		2,4,6,8			254																							765	
180M			279	139.5	240	121	48	110		14	42.5	180	15	300	250	350												825	
180L					279													19	5									875	
200L	FF350		318	159	305	133	55		16	49	200			350	300	400												900	
225S		4,8			286		60	140	18	53		19																1000	
225M	FF400	2	356	178	311	149	55	110	16	49	225			400	350	450												1000	
		4,6,8					60	140	18	53																		1030	

Note:R is the distance from the flange mounting plate to the shaft extension shoulder.

注意: R是从凸缘安装平面到轴伸肩的距离。

电磁制动三相异步电动机

TECHNICAL DATA 技术参数

Type 型号	Rated Output 功率		Speed 转速 (r/min)	Current 电流 (A)	Eff 效率 (%)	Power factor 功率因数 (cosφ)	堵转电流	堵转转矩	最大转矩	Exciting Voltage 励磁电压 (V)	Static braking torque not less than (N.m) 静态制动扭矩	No-load brake lag time limitation (s) 空载制动延迟时间
	KW	Hp					Ist/In	Tst/Tn	Tmax/Tn			
YEJ系列电机技术参数 / Technical data – YEJ series motor – 2 Poles – 380V/50Hz												
801-2	0.75	1	2825	1.9	73	0.84	7	2.2	2.2	100	7.36	0.2
802-2	1.1	1.5	2825	2.6	76	0.86	7	2.2	2.2	100	7.36	0.2
90S-2	1.5	2	2840	3.4	79	0.85	7	2.2	2.2	100	14.7	0.25
90L-2	2.2	3	2840	4.7	82	0.86	7	2.2	2.2	100	14.7	0.25
100L-2	3	4	2880	6.4	82	0.87	7	2.2	2.2	100	29.4	0.3
112M-2	4	5.5	2890	8.2	85.5	0.87	7	2.2	2.2	170	39.2	0.35
132S1-2	5.5	7.5	2900	11.1	86.2	0.88	7	2.2	2.2	170	73.6	0.4
132S2-2	7.5	10	2900	15	86.2	0.88	7	2.2	2.2	170	73.6	0.4
160M1-2	11	15	2930	21.8	87.2	0.88	7	2.2	2.2	170	147.2	0.5
160M2-2	15	20	2930	29.4	88.2	0.88	7	2.2	2.2	170	147.2	0.5
160L-2	18.5	25	2930	35.5	89	0.89	7	2.2	2.2	170	147.2	0.5
180M-2	22	30	2940	42.2	89	0.89	7	2.2	2.2	170	215.8	0.6
200L1-2	30	40	2950	56.9	90	0.89	7	2.2	2.2	170	294.3	0.7
200L2-2	37	50	2950	69.8	90.5	0.89	7	2.2	2.2	170	294.3	0.7
225M-2	45	60	2970	83.9	91.5	0.89	7	2.2	2.2	170	441.5	0.8
YEJ系列电机技术参数 / Technical data – YEJ series motor – 4 Poles – 380V/50Hz												
801-4	0.55	0.75	1390	1.6	70.5	0.76	6.5	2.2	2.2	100	7.36	0.2
802-4	0.75	1	1390	2.1	72.5	0.76	6.5	2.2	2.2	100	7.36	0.2
90S-4	1.1	1.5	1400	2.7	79	0.78	6.5	2.2	2.2	100	14.7	0.25
90L-4	1.5	2	1400	3.7	79	0.79	6.5	2.2	2.2	100	14.7	0.25
100L1-4	2.2	3	1420	5	81	0.82	7	2.2	2.2	100	29.4	0.3
100L2-4	3	4	1420	6.8	82.5	0.81	7	2.2	2.2	100	29.4	0.3
112M-4	4	5.5	1440	8.8	84.5	0.82	7	2.2	2.2	170	39.2	0.35
132S-4	5.5	7.5	1440	11.6	85.5	0.84	7	2.2	2.2	170	73.6	0.4
132M-4	7.5	10	1440	15.4	87	0.85	7	2.2	2.2	170	73.6	0.4
160M-4	11	15	1460	22.6	88	0.84	7	2.2	2.2	170	147.2	0.5
160L-4	15	20	1460	30.3	88.5	0.85	7	2.2	2.2	170	147.2	0.5
180M-4	18.5	25	1470	35.9	91	0.86	7	2.2	2.2	170	215.8	0.6
180L-4	22	30	1470	42.5	91.5	0.86	7	2.2	2.2	170	215.8	0.6
200L-4	30	40	1470	56.8	92.5	0.87	7	2.2	2.2	170	294.3	0.7
225S-4	37	50	1480	69.8	91.8	0.87	7	2.2	2.2	170	414.5	0.8
	45	60	1480	84.2	92.3	0.88	7	2.2	2.2	170	414.5	0.8

TECHNICAL DATA 技术参数

Type 型号	Rated Output 功率		Speed 转速 (r/min)	Current 电流 (A)	Eff 效率 (%)	Power factor 功率因数 (cosφ)	堵转电流	堵转转矩	最大转矩	Exciting Voltage 励磁电压 (V)	Static braking torque not less than (N.m) 静态制动扭矩	No-load brake lag time limitation (s) 空载制动延迟时间
	KW	Hp					Ist/In	Tst/Tn	Tmax/Tn			
YEJ系列电机技术参数 / Technical data – YEJ series motor – 6 Poles – 380V/50Hz												
90S-6	0.75	1	910	2.3	72.5	0.7	6	2	2.2	100	14.7	0.25
90L-6	1.1	1.5	910	3.2	73.5	0.72	6	2	2	100	14.7	0.25
100L-6	1.5	2	940	4	77.5	0.74	6	2	2	100	29.4	0.3
112M-6	2.2	3	940	5.6	80.5	0.74	6	2	2	170	39.2	0.35
132S-6	3	4	960	7.2	83	0.76	6.5	2	2	170	73.6	0.4
132M1-6	4	5.5	960	9.4	84	0.77	6.5	2	2	170	73.6	0.4
132M2-6	5.5	7.5	960	12.6	85.3	0.78	6.5	2	2	170	73.6	0.4
160M-6	7.5	10	970	17	86	0.78	6.5	2	2	170	147.2	0.5
160L-6	11	15	970	24.6	86	0.78	6.5	2	2	170	147.2	0.5
180L-6	15	20	970	31.4	89.5	0.81	6.5	1.8	2	170	215.8	0.6
200L1-6	18.5	25	970	37.7	89.8	0.83	6.5	1.8	2	170	294.2	0.7
200L2-6	22	30	970	44.6	90.2	0.83	6.5	1.8	2	170	294.2	0.7
225M-6	30	40	980	59.5	90.2	0.85	6.5	1.8	2	170	441.5	0.8
YEJ系列电机技术参数 / Technical data – YEJ series motor – 8 Poles – 380V/50Hz												
132S-8	2.2	3	710	5.8	81	0.71	5.5	2	2	170	73.6	0.4
132M-8	3	4	710	7.7	82	0.72	5.5	2	2.2	170	73.6	0.4
160M1-8	4	5.5	720	9.9	84	0.73	6	2	2	170	147.2	0.5
160M2-8	5.5	7.5	720	13.3	85	0.74	6	2	2	170	147.2	0.5
160L-8	7.5	10	720	17.3	86	0.75	5.5	2	2	170	147.2	0.5
180L-8	11	15	730	27.7	86.5	0.77	6	1.7	2	170	215.8	0.6
200L-8	15	20	730	34.1	88	0.76	6	1.8	2	170	294.3	0.7
225S-8	18.5	25	730	41.3	89.5	0.76	6	1.7	2	170	441.5	0.8
225M-8	22	30	730	47.6	90	0.78	6	1.8	2	170	441.5	0.8

变频多速三相异步电动机

PRODUCT OVERVIEW 产品概述

YD系列电机采用绕组变极方法实现速度变换，其性能指标符合国际IEC标准。广泛应用于各类有级调速机械设备，使整机结构紧凑、噪音降低、节约能源。

YD series motors can achieve multi-speed by changing the winding poles, all the performance are in accordance with IEC standard. It is widely used on the step speed regulation machinery, and makes them compact conformation, lower noise and energy conservation.

TECHNICAL DATA 技术参数

机座中心高：80~280mm

功率范围：0.35~82kW

额定电压：380V (其他电压需另订协议)

额定频率：50Hz (或60Hz)

防护等级：IP54 (或IP55)

绝缘等级：B/F级

工作制：S1

Centre height of frame:80~280mm

Power range:0.35~82kW

Rated voltage:380V(special should order)

Rated frequency:50Hz or 60Hz

Protection class:IP54 or IP55

Insulation class:B/F

Duty type:S1



TECHNICAL DATA 技术参数

Type 型号		Output 功率 KW	Speed 转速 (r/min)	Current 电流 (A)	Eff 效率 (%)	P.F. 功率因素 cosφ	堵转电流 额定电流 Ist/In	堵转转矩 额定转矩 Tst/Tn	最大转矩 额定转矩 Tmax/Tn
YD801	4	0.45	1420	1.4	66	0.74	6.5	1.5	1.8
	2	0.55	2860	1.5	65	0.85	7	1.6	
YD802	4	0.55	1420	1.7	68	0.74	6.5	1.5	
	2	0.75	2860	2	66	0.85	7	1.6	
YD90S	4	0.85	1430	2.3	74	0.77	6.5	1.5	
	2	1.1	2850	2.8	73	0.84	7	1.6	
YD90L	4	1.3	1430	3.3	76	0.78	6.5	1.5	
	2	1.8	2850	4.3	74	0.84	7	1.6	
YD100L1	4	2	1430	4.8	78	0.81	6.5	1.5	
	2	2.4	2850	5.6	76	0.86	7	1.6	
YD100L2	4	2.4	1430	5.6	79	0.83	6.5	1.5	
	2	3	2850	6.7	77	0.89	7	1.6	
YD112M	4	3.3	1450	7.4	81	0.83	6.5	1.5	
	2	4	2860	8.6	80	0.88	7	1.6	
YD132S	4	4.5	1450	9.8	83	0.84	6.5	1.5	
	2	5.5	2860	11.9	79	0.88	7	1.6	
YD132M	4	6.5	1450	13.8	84	0.85	6.5	1.5	
	2	8	2880	17.1	80	0.89	7	1.6	
YD160M	4	9	1460	18.5	87	0.85	6.5	1.5	
	2	11	2920	22.9	82	0.89	7	1.6	
YD160L	4	11	1460	22.3	87	0.86	6.5	1.5	
	2	14	2920	28.8	82	0.9	7	1.6	
YD180M	4	14	1470	29.4	89	0.87	6.5	1.5	
	2	18.5	2940	36.7	85	0.9	7	1.6	
YD180L	4	18.5	1470	25.9	89	0.88	6.5	1.5	
	2	22	2940	42.7	86	0.91	7	1.6	
YD200L	4	26	1470	49.9	89	0.89	6.5	1.4	
	2	30	2950	58.3	85	0.92	7	1.4	

变频多速三相异步电动机

TECHNICAL DATA 技术参数

Type 型号	Output 功率 KW	Speed 转速 (r/min)	Current 电流 (A)	Eff 效率 (%)	P.F. 功率因素 cosφ	堵转电流 额定电流 Ist/In	堵转转矩 额定转矩 Tst/Tn	最大转矩 额定转矩 Tmax/Tn
YD225S	4	32	1480	60.7	0.89	6.5	1.4	1.8
	2	37	2960	71.7	0.92	7	1.4	
YD225M	4	37	1480	69.4	0.89	6.5	1.4	
	2	45	2960	86.4	0.92	7	1.4	
YD250M	4	45	1480	84.4	0.89	6.5	1.4	
	2	55	2960	103.2	0.92	7	1.4	
YD280S	4	60	1480	111.3	0.9	6.5	1.4	
	2	72	2970	135.1	0.92	7	1.4	
YD280M	4	72	1480	133.6	0.9	6.5	1.4	
	2	80	2970	152.2	0.93	7	1.4	
YD90S	6	0.65	920	2.2	0.7	6	1.4	
	4	0.85	1420	2.3	0.79	6.5	1.3	
YD90L	6	0.85	930	2.8	0.7	6	1.4	
	4	1.1	1420	3	0.79	6.5	1.3	
YD100L1	6	1.3	940	3.8	0.7	6	1.4	
	4	1.8	1440	4.4	0.8	6.5	1.3	
YD100L2	6	1.5	940	4.3	0.7	6	1.4	
	4	2.2	1440	5.4	0.8	6.5	1.3	
YD112M	6	2.2	960	5.7	0.75	6	1.4	
	4	2.8	1440	6.7	0.82	6.5	1.3	
YD132S	6	3	960	7.7	0.7	6	1.4	
	4	4	1440	9.5	0.82	6.5	1.3	
YD132M	6	4	960	9.8	0.76	6	1.4	
	4	5.5	1440	12.3	0.85	6.5	1.3	
YD160M	6	6.5	970	15.1	0.78	6	1.4	
	4	8	1460	17.4	0.85	6.5	1.3	
YD160L	6	9	970	20.6	0.78	6	1.4	
	4	11	1460	23.4	0.85	6.5	1.3	
YD180M	6	11	980	25.9	0.78	6	1.4	
	4	14	1470	29.8	0.85	6.5	1.3	
YD180L	6	13	980	29.4	0.78	6	1.4	
	4	16	1470	33.6	0.85	6.5	1.3	

TECHNICAL DATA 技术参数

Type 型号	Output 功率 KW	Speed 转速 (r/min)	Current 电流 (A)	Eff 效率 (%)	P.F. 功率因素 cosφ	堵转电流 额定电流 Ist/In	堵转转矩 额定转矩 Tst/Tn	最大转矩 额定转矩 Tmax/Tn
YD200L	6	18.5	980	41.4	0.78	6.5	1.4	1.8
	4	22	1460	44.7	0.86	7	1.3	
YD225S	6	22	980	44.2	0.86	6.5	1.4	
	4	28	1470	56.2	0.87	7	1.3	
YD225M	6	26	980	52.2	0.86	6.5	1.4	
	4	34	1470	66	0.9	7	1.3	
YD250M	6	32	980	62.1	0.87	6.5	1.4	
	4	42	1470	74.7	0.91	7	1.3	
YD280S	6	42	980	81.5	0.87	6.5	1.4	
	4	55	1470	104.2	0.9	7	1.3	
YD280M	6	55	990	106.7	0.87	6.5	1.4	
	4	72	1480	138.1	0.89	7	1.3	
YD90L	8	0.45	680	1.9	0.63	5.5	1.5	
	4	0.75	1420	1.92	0.87	6.5	1.5	
YD100L	8	0.85	700	3.1	0.63	5.5	1.5	
	4	1.5	1420	3.5	0.88	6.5	1.5	
YD112M	8	1.5	700	5	0.63	5.5	1.5	
	4	2.4	1420	5.3	0.88	6.5	1.5	
YD132S	8	2.2	720	7	0.64	5.5	1.5	
	4	3.3	1440	7.1	0.88	6.5	1.5	
YD132M	8	3	720	9	0.65	5.5	1.5	
	4	4.5	1440	9.4	0.88	6.5	1.5	
YD160M	8	5	730	13.9	0.66	5.5	1.5	
	4	7.5	1450	15.2	0.89	6.5	1.5	
YD160L	8	7	730	19	0.66	5.5	1.5	
	4	11	1450	21.8	0.89	6.5	1.5	
YD180L	8	11	730	26	0.74	6	1.5	
	4	17	1470	31.5	0.92	7	1.5	
YD200L1	8	14	740	33	0.74	6	1.5	
	4	22	1470	41.3	0.92	7	1.5	
YD200L2	8	17	740	40.1	0.74	6	1.5	
	4	26	1470	48.8	0.92	7	1.5	
YD225M	8	24	740	53.2	0.77	6	1.4	
	4	34	1470	66.7	0.88	7	1.3	

变频多速三相异步电动机

TECHNICAL DATA 技术参数

Type 型号	Output 功率 KW	Speed 转速 (r/min)	Current 电流 (A)	Eff 效率 (%)	P.F. 功率因素 cosφ	堵转电流 额定电流 Ist/In	堵转转矩 额定转矩 Tst/Tn	最大转矩 额定转矩 Tmax/Tn
YD250M	8	30	740	64.9	90	0.78	6	1.4
	4	42	1480	78.8	89	0.91	7	1.3
YD280S	8	40	740	83.5	91	0.8	6	1.4
	4	55	1480	102	90	0.91	7	1.3
YD280M	8	47	740	96.9	91	0.81	6	1.4
	4	67	1480	122.9	90	0.92	7	1.3
YD90S	8	0.35	680	1.6	56	0.6	5	1.5
	6	0.45	930	1.4	70	0.72	6	1.5
YD90L	8	0.45	680	1.9	59	0.6	5	1.5
	6	0.65	930	1.9	71	0.73	6	1.5
YD100L	8	0.75	710	2.9	65	0.6	5	1.5
	6	1.1	950	3.1	75	0.73	6	1.5
YD112M	8	1.3	710	4.5	72	0.61	5	1.5
	6	1.8	950	4.8	78	0.73	6	1.5
YD132S	8	1.8	730	5.8	75	0.62	5	1.5
	6	2.4	970	6.2	80	0.73	6	1.5
YD132M	8	2.6	730	8.2	78	0.62	5	1.5
	6	3.7	970	9.4	82	0.73	6	1.5
YD160M	8	4.5	930	13.3	83	0.62	5	1.5
	6	6	980	14.7	85	0.73	6	1.5
YD160L	8	6	930	17.5	84	0.62	5	1.5
	6	8	980	19.4	86	0.73	6	1.5
YD180M	8	7.5	930	21.9	84	0.62	5	1.5
	6	10	980	24.2	86	0.73	6	1.5

1.8

TECHNICAL DATA 技术参数

Type 型号	Output 功率 KW	Speed 转速 (r/min)	Current 电流 (A)	Eff 效率 (%)	P.F. 功率因素 cosφ	堵转电流 额定电流 Ist/In	堵转转矩 额定转矩 Tst/Tn	最大转矩 额定转矩 Tmax/Tn
YD180L	8	9	730	24.8	85	0.65	5	1.5
	6	12	980	28.3	86	0.75	6	1.5
YD200L1	8	12	730	32.5	86	0.65	5	1.5
	6	17	980	39.1	87	0.76	6	1.5
YD200L2	8	15	730	40.3	87	0.65	5	1.5
	6	20	980	45.4	88	0.76	6	1.5
YD100L	6/4/2	0.75/1.3/1.8	940/1420/2880	2.62/3.66/4.53	67/72/71	0.65/0.75/0.85	5.5/6/7	1.8/1.6/1.6
YD112M	6/4/2	1.1/2/2.4	940/1440/2890	3.52/5.14/5.8	73/74/74	0.65/0.81/0.85	5.5/6/7	1.7/1.4/1.6
YD132S	6/4/2	1.8/2.6/3	940/1440/2900	5.14/6.1/7.38	75/78/71	0.71/0.83/0.87	5.5/6/7	1.4/1.3/1.7
YD132M1	6/4/2	2.2/3.3/4	940/1440/2900	6.03/7.46/8.79	77/80/76	0.72/0.84/0.91	5.5/6/7	1.3/1.3/1.7
YD132M2	6/4/2	2.6/4/5	940/1440/2900	6.86/9.04/10.8	80/80/77	0.72/0.84/0.91	5.5/6/7	1.5/1.4/1.7
YD160M	6/4/2	3.7/5/6	970/1490/2930	9.52/11.2/13.2	81/81/76	0.72/0.84/0.91	5.5/6/7	1.5/1.3/1.4
YD160L	6/4/2	4.5/7/9	910/1460/2930	11.4/15.1/18.8	83/83/79	0.72/0.85/0.92	5.5/6/7	1.5/1.2/1.3
YD112M	8/4/2	0.65/2/2.4	710/1440/2900	2.66/5.14/5.8	59/74/74	0.63/0.81/0.85	4.5/6/7	1.4/1.3/1.2
YD132S	8/4/2	1/2.6/3	710/1440/2900	3.16/6.1/7.08	69/78/74	0.61/0.83/0.87	4.5/6/7	1.4/1.2/1.4
YD132M	8/4/2	1.3/3.7/4.5	710/1440/2900	4.56/8.37/10	71/80/75	0.61/0.84/0.91	4.5/6/7	1.5/1.3/1.4
YD160M	8/4/2	2.2/5/6	720/1460/2930	7.55/11.2/13.2	75/81/76	0.59/0.84/0.91	4.5/6/7	1.4/1.3/1.4
YD160L	8/4/2	2.8/7/9	720/1460/2930	9.21/15.1/18.8	77/83/79	0.6/0.85/0.92	4.5/6/7	1.3/1.2/1.3
YD112M	8/4/2	0.85/1/1.5	710/940/1400	3.72/3.06/3.53	62/68/75	0.56/0.73/0.86	5.5/6.5/7	1.4/1.2/1.4
YD132S	8/4/2	1.1/1.5/1.8	710/940/1440	4.1/4.22/4.03	68/74/78	0.6/0.73/0.87	5.5/6.5/7	1.4/1.3/1.3
YD132M1	8/4/2	1.5/2/2.2	710/940/1440	5.18/5.41/4.87	71/77/79	0.62/0.73/0.87	5.5/6.5/7	1.3/1.5/1.4
YD132M2	8/4/2	1.8/2.6/3	710/940/1440	6.13/6.84/6.55	72/78/80	0.62/0.74/0.87	5.5/6.5/7	1.5/1.5/1.5
YD160M	8/4/2	8.3/4/5.5	720/970/1460	10.2/9.87/11.6	79/81/83	0.62/0.76/0.87	5.5/6.5/7	1.7/1.4/1.5
YD160L	8/4/2	4.5/6/7.5	720/970/1460	13.8/14.5/15.6	80/83/84	0.62/0.76/0.87	5.5/6.5/7	1.6/1.6/1.5

1.8/1.8/1.8

变频多速三相异步电动机

适用范围:YC可作为空气压缩机、电冰箱、医疗器械等机械的动力装置。

特点:起动转矩较大,性能优良,节能省电,结构可靠,通用性强。基本系列电机额定电源为220V/50Hz,根据需要可提供110/220V、110V、240V/60Hz等电动机,可采用铸铝机壳或铸铁机壳。

Applications: As a drive device of compressors, refrigerator remedy apparatus and machine tools etc.
Features: High starting torque, low energy consumption. Cast iron or cast aluminum frames.
The basic type is rated at 220V/50HZ. 110V/220V, 110V, 240V with 60Hz are also available according to requirements.

OPERATING CONDITIONS 使用条件

机座号: 71~132 Ambient temperature: $-15^{\circ}\text{C} < 0 < 40^{\circ}\text{C}$
功率: 0.12~3.7KW Altitude: Not exceeding 1000m
工作制: S1 Rated voltage: 220V/110V
绝缘等级: B Rated frequency: 50Hz/60Hz



TECHNICAL DATA 技术参数

额定电压: 220V 频率: 50Hz Rated Voltage: 220V Frequency: 50Hz

Type 型号	Rated Output 功率		Current 功率(A)	P.F. 功率因素 $\cos\phi$	Eff 效率 (%)	Speed 转速 (r/min)	Ist 堵转电流 (A)	堵转转矩 额定转矩 T_{st}/T_n	最大转矩 额定转矩 T_{max}/T_n
	KW	Hp							
YC711-2	0.18	1/4	2.3	0.72	60	2800	12	3	1.8
YC712-2	0.25	1/3	2.9	0.74	64	2800	15	3	
YC801-2	0.37	1/2	3.77	0.77	65	2800	21	2.8	
YC802-2	0.55	3/4	5.19	0.79	68	2800	29	2.8	
YC90S-2	0.75	1	6.4	0.82	70	2800	37	2.5	
YC90L1-2	1.1	1.5	8.47	0.82	72	2800	80	2.5	
YC90L2-2	1.5	2	11.3	0.81	74	2800	80	2.5	
YC100L1-2	1.5	2	11.3	0.81	74	2800	80	2.5	
YC100L2-2	2.2	3	16.5	0.81	75	2800	120	2.2	
YC112M-2	3	4	21.9	0.82	76	2800	150	2.2	
YC132S-2	3.7	5	26.6	0.82	77	2800	175	2.2	
YC711-4	0.12	1/6	1.88	0.58	50	1400	9	3	
YC712-4	0.18	1/4	2.49	0.62	53	1400	12	2.8	
YC801-4	0.25	1/3	3.11	0.63	58	1400	15	2.8	
YC802-4	0.37	1/2	4.24	0.64	62	1400	21	2.5	
YC90S-4	0.55	3/4	5.49	0.69	66	1400	29	2.5	
YC90L1-4	0.75	1	6.87	0.73	68	1400	37	2.5	
YC90L2-4	1.1	1.5	9.52	0.74	71	1400	80	2.5	
YC100L1-4	1.1	1.5	9.52	0.74	71	1400	80	2.5	
YC100L2-4	1.5	2	12.5	0.75	73	1400	80	2.5	
YC112M-4	2.2	3	17.8	0.76	74	1400	120	2.2	
YC132S-4	3	4	23.6	0.77	75	1400	150	2.2	
YC132M-4	3.7	5	28	0.79	76	1400	175	2.2	

电容启动异步电动机

YL系列双值电容异步电动机系电容启动运行的单相异步电动机,主要特征:体积小、容量大、启动力矩大、效率高、运行安全可靠、结构简单、容易维护。该电动机拥有6个机座,其容量相当于三相异步电动机。该系列电动机全部采用全封闭、外扇冷式结构,适用于满负荷启动的机械设备。

YL Series two-value capacitor single-phase asynchronous motors are run by capacitor. Main features are small size, high capacity, strong starting torque, high power factor and efficiency, safe and reliable in running, simple construction and easy to maintain. It possess 6 engine bases and its capacity is equal to three-phase asynchronous motors. This series motors is totally enclosed fan-cooled structure, and is suitable for machines and equipments that starts at full load.

OPERATING CONDITIONS 使用条件

机座号: 71~132 Ambient temperature: $-15^{\circ}\text{C} < 0 < 40^{\circ}\text{C}$
功率: 0.12~3.7KW Altitude: Not exceeding 1000m
工作制: S1 Rated voltage: 220V/110V
绝缘等级: B Rated frequency: 50Hz/60Hz

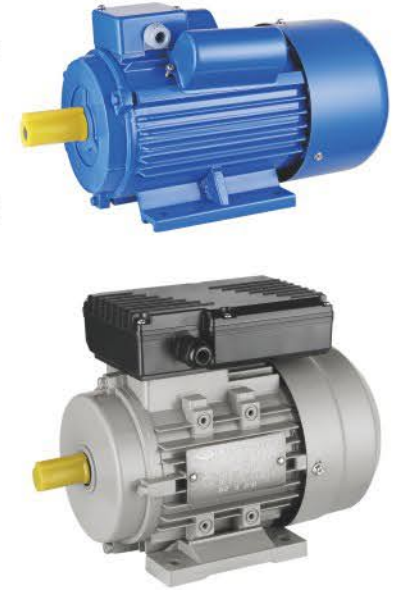

TECHNICAL DATA 技术参数

额定电压: 220V 频率: 50Hz Rated Voltage: 220V Frequency: 50Hz

Type 型号	Rated Output 功率		Current 功率(A)	P.F. 功率因素 $\cos\phi$	Eff 效率 (%)	Speed 转速 (r/min)	Ist 堵转电流 (A)	堵转转矩 额定转矩 T_{st}/T_n	最大转矩 额定转矩 T_{max}/T_n
	KW	Hp							
YL711-2	0.37	1/2	2.73	0.92	67	2750	16	1.8	1.7
YL712-2	0.55	3/4	3.88	0.92	70	2750	21	1.8	
YL801-2	0.75	1	4.78	0.92	72	2800	29	1.8	
YL802-2	1.1	1.5	6.93	0.95	75	2820	40	1.8	
YL90S-2	1.5	2	9.44	0.95	76	2820	55	1.7	
YL90L-2	2.2	3	13.7	0.95	77	2830	80	1.7	
YL100L-2	3	4	18.4	0.95	79	2850	110	1.7	
YL112M-2	3.7	5	22.1	0.95	80	2850	160	1.7	
YL711-4	0.25	1/3	1.99	0.92	62	1360	12	1.8	
YL712-4	0.37	1/2	2.81	0.92	65	1360	16	1.8	
YL801-4	0.55	3/4	3.77	0.92	68	1400	21	1.8	
YL802-4	0.75	1	5.08	0.92	71	1400	29	1.8	
YL90S-4	1.1	1.5	7.02	0.95	73	1410	40	1.7	
YL90L-4	1.5	2	9.44	0.95	75	1420	55	1.7	
YL100L1-4	2.2	3	13.7	0.95	76	1430	80	1.7	
YL100L2-4	3	4	18.4	0.95	77	1430	110	1.7	
YL112M1-4	3	4	18.4	0.95	77	1430	110	1.7	
YL112M2-4	3.7	5	22.1	0.95	80	1450	138	1.7	
YL132S1-4	3.7	5	22.1	0.95	80	1450	138	1.7	
YL132S2-4	5.5	7.5	32.5	0.95	81	1450	227	1.7	

变频驱动永磁同步电动机

目前永磁同步电机主要应用于数控铣床、车床以及注塑机上。永磁同步电机需要搭配变频控制器使用。它和普通矢量变频器不一样，是直流变频技术，可以以恒功率、恒转速、恒扭矩等工作方式工作；具有响应速度快，控制精确的特点，它在整个功率负载段输出功率曲线都平坦，电机效率方面的全段也都是高效率。永磁同步电机和一般常用功率的异步电机相比，效率要高很多。永磁同步电机还有一个特点就是速度越高优势越明显，它的转速可以根据要求来设计。速度高时，电机体积小，耗材少，单位功率的成本也低。

At present, permanent magnet synchronous motor is mainly used in CNC milling machine, lathe and injection molding machine. Permanent magnet synchronous motor needs to match the frequency conversion controller when using. It adopts dc frequency conversion technology which enables it to respond quickly and control precisely under constant power, constant speed and constant torque working mode. Besides, the output power is also constant.

Compared with general asynchronous motor, the efficiency of this kind motor is much higher. When the higher the speed, its speed can be designed according to the requirements. Furthermore, the rotate speed of this kind of motor can be customized. Even when the rotational speed required to be high, the motor size can be small, and the unit power can be low.

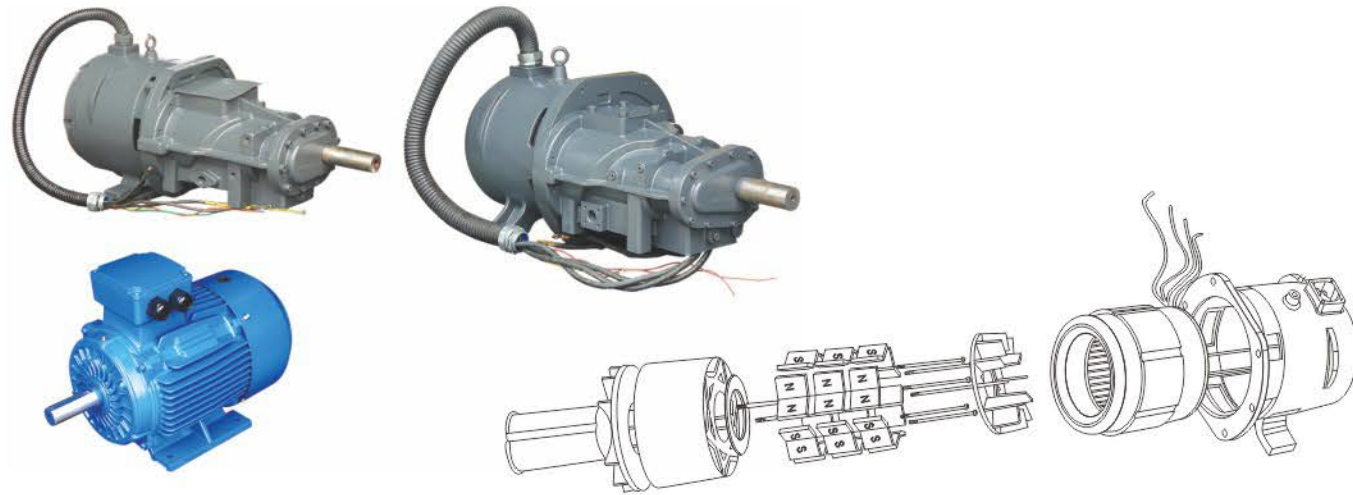

TECHNICAL DATA 技术参数

序号 No.	型号 Type	机座号或 法兰号 Frame or Flange No.	额定转速 Rated Speed (r/min)	额定转矩 Rated Torque (Nm)	额定功率 Rated Output (KW)	额定电压 Rated Voltage (V)	频率 Frequency (Hz)	绝缘等级 Insulation Class	防护等级 Protection class	冷却方式 Cooling Method	工作制 Duty	效率 Efficiency (%)	总重 Weight (kg)
1	TYP112-8G	112	2200	23.9	5.5	380	50	F	IP23	IC01	S1	89.8	48
2	TYP112-8F	112	3000	2.9	7.5	380	50	F	IP23	IC01	S1	89.8	48
3	TYP132-8G	132	2200	47.8	11	380	50	F	IP23	IC01	S1	90.6	82
4	TYP132-8F	132	3000	47.8	15	380	50	F	IP23	IC01	S1	91.3	82
5	TYP160-8G	160	2500	70.7	18.5	380	50	F	IP23	IC01	S1	92.5	125
6	TYP160-8F	160	3000	70.0	22	380	50	F	IP23	IC01	S1	92.5	125
7	TYP180-8G	180	2300	124.6	30	380	50	F	IP23	IC01	S1	93.5	190
8	TYP180-8F	180	3000	117.8	37	380	50	F	IP23	IC01	S1	93.6	190
9	TYP180-8E	180	3600	119.4	45	380	50	F	IP23	IC01	S1	94.0	200
10	TYP225-6I	225	1500	235.6	37	380	50	F	IP23	IC01	S1	93.9	440
11	TYP225-6G	225	2300	228.4	55	380	50	F	IP23	IC01	S1	94.6	440
12	TYP225-6F	225	3000	238.8	75	380	50	F	IP23	IC01	S1	94.8	440
13	TYP225-6E	225	3600	238.8	90	380	50	F	IP23	IC01	S1	95.2	460
14	TYP280-6I	280	1500	573	90	380	50	F	IP23	IC01	S1	95.2	680

INSTALLATION SIZE 安装尺寸 (mm)

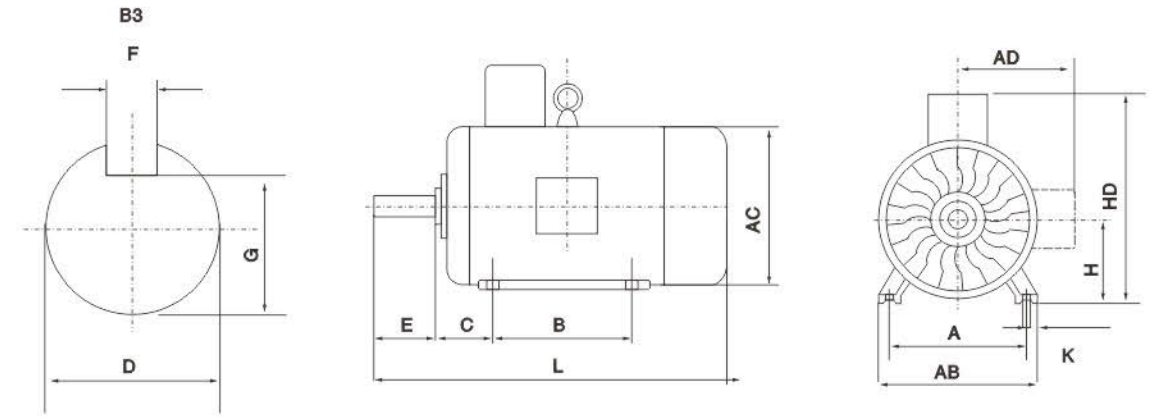

Frame size 型号尺寸	Flange no 凸缘型号	Poles 极数	Mounting dimensions(mm) 安装尺寸 (mm)																Flange holes 凸缘孔	Overall dimensions(mm) 外形尺寸 (mm)				
			A	A/2	B	C	D	E	F	G	H	K	M	N	P	R	S	T		AB	AC	AD	HD	L
63M	FF115	2,4	100	50	80	40	11	23	4	8.5	63		115	95	140			3	135	130	70	180	230	
71M	FF130	2,4,6	112	56	90	45	14	30	5	11	71	7	130	110	160			10	150	145	80	195	255	
80M			125	62.5	100	50	19	40	6	15.5	80		165	130	200			12	165	175	145	220	295	
90S	FF165		140	70		56	24	50		20	90		10	165	130	200			12	180	195	155	250	320
90L					125																			345
100L	FF215		160	80		63		60		8	100			215	180	250								385
112M			190	95	140	70	28	60		24	112	12		230	240	300	400		15	230	240	190	300	400
132S	FF265	2,4,6,8	216	108		89	38	80	10	33	132			265	230	300								470
132M					178																			510
160M			254	127		210	108	42		12	37	160												615
160L	FF300				254																			670
180M			279	139.5		240	121	48	110		14	42.5	180	15	300	250	350							700
180L					279																			740
200L	FF350		318	159	305	133	55			16	49	200		350	300	400								770
225S		4,8			286		60	140	18	53														815
225M	FF400	2	356	178		311	149		55	110	16	49	225	19	400	350	450		19	435	470	335	560	820
		4,6,8																						845
250M		2	406	203	349	168		60			53													
		4,6,8									18													
280S	FF500	2				65					58													
280M		4,6,8	457	228.5		368	190		75	140	20	67.5	280		500	450	550							985
		2				419			65		18	58												1035
		4,6,8							75		20	67.5												
315S		2				65					18	58												1160
		4,6,8,10				406			80	170	22	71												1270
315M	FF600	2	508	254	457	216			65	140	18	58			600	550	660							1190
		4,6,8,10							80	170	22	71	315											1300
315L		2				508			65	140	18	58												1190
		4,6,8,10							80	170	22	71												1300
355L		2				560			75	140	20	67.5												1500
		4,6,8,10							95	170	25	86												1530
355M	FF740	2	610	305		254			75	140	20	67.5	155		740	680	800							1500
		4,6,8,10				630			95	170	25	86												1530

Note: R is the distance from the flange mounting plate to the shaft extension shoulder.
注意: R是从凸缘安装平面到轴伸肩的距离。

三相感应电动机

使用条件:

在下列高度和环境气温条件下,电动机在额定情况下运行。

1. 海拔不超过1000米
2. 环境最高气温随季节变化,但不超过400°C
注:如果电机指定使用要在海拔1000米以上或最大环境空气温度高于或低于40°C的环境下使用,应符合GB755-2008的要求。
3. 使用环境空气温度最低为15°C
4. 电机运行时,电源电压和频率偏差额定值应符合GB755的要求。
5. 电动机的效率由间接损耗分析决定,0.5%的杂散损耗在额定输入端计算,非额定端由杂散损耗电流二次变换计算。
6. 电机效率计算时,电机绕组电阻基准温度应由95°C、130(B)绝缘等级转换为115°C、155(F)绝缘等级(根据GB/T1032要求)。



Conditions of use:

Under the following conditions of altitude and the ambient air temperature, the motor should be rated operation

1. The altitude does not exceed 1000m
2. The maximum ambient air temperature changes with the seasons' area, but not more than 400°C
Note: If the motor is specified using an altitude of over 1000m or under conditions of maximum ambient air temperature is higher or lower than 40°C when should GB755-2008 requirements
3. The lowest ambient air temperature is -15°C.
4. The power supply voltage and frequency deviation ratings should follow GB755's requirement during motor operation.
5. The efficiency of the motor is determined by the indirect loss analysis; 0.5% stray loss is calculated at rated input calculates non-rated point by stray loss current quadratic conversion.
6. When the motor efficiency calculations, the reference temperature of the motor winding resistance should be converted from 95 °C, 130 (B) insulation class to 115°C when 155(F) insulation class (according to GB/T1032 requirements).

TECHNICAL DATA 技术参数

额定电压: 380V 频率: 50Hz Rated Voltage:380V Frequency:50Hz

Type 型号	Rated Output 功率		Eff 效率 (%)	P.F. 功率因素 cosφ	堵转电流 额定电流 Ist/In	堵转转矩 额定转矩 Tst/Tn	最小转矩 Lmin/Tn	最大转矩 额定转矩 Tmax/Tn
	Kw	Hp						
2 Poles Synchronous Speed 3000 r/min 2极 同步转速 3000 r/min								
160M	15	20	80.0	0.88	7.0	1.7	1.2	2.2
160L1	18.5	25	89.0	0.89	7.0	1.8	1.1	2.2
160L2	22	30	89.5	0.89	7.0	2.0	1.1	2.2
180M	30	40	89.5	0.89	7.0	1.7	1.1	2.2
180L	37	50	90.5	0.89	7.0	1.9	1.1	2.2
200M	45	60	91.0	0.89	7.0	1.9	0.9	2.2
200L	55	75	91.5	0.89	7.0	1.9	0.9	2.2
225M	75	100	91.5	0.89	6.7	1.8	0.8	2.2
250S	90	120	92.0	0.89	6.8	1.7	0.8	2.2
250M	110	150	92.5	0.90	6.8	1.7	0.8	2.2
280S	-	-	-	-	-	-	-	-
280M	132	176	92.5	0.90	6.8	1.6	0.8	2.2
315S	160	215	92.5	0.90	6.8	1.4	0.83	2.0
315M1	(185)	247	92.5	0.90	6.8	1.4	0.71	2.0
315M2	200	267	93.0	0.90	6.8	1.4	0.71	2.0
315M3	(220)	300	93.0	0.90	6.8	1.4	0.71	2.0
315M4	250	335	93.8	0.88	6.8	1.2	0.71	2.0
355M1	-	-	-	-	-	-	-	-
355M2	(280)	375	94.0	0.88	6.5	1.0	0.71	1.8
355M3	315	420	94.0	0.89	6.5	1.0	0.71	1.8
355M4	-	-	-	-	-	-	-	-
355L1	355	475	94.3	0.89	6.5	1.0	0.71	1.8
355L2	-	-	-	-	-	-	-	-

TECHNICAL DATA 技术参数

额定电压: 380V 频率: 50Hz Rated Voltage:380V Frequency:50Hz

Type 型号	Rated Output 功率		Eff 效率 (%)	P.F. 功率因素 cosφ	堵转电流 额定电流 Ist/In	堵转转矩 额定转矩 Tst/Tn	最小转矩 Lmin/Tn	最大转矩 额定转矩 Tmax/Tn
	Kw	Hp						
4 Poles Synchronous Speed 1500 r/min 2极 同步转速 1500 r/min								
160M	11	15	87.5	0.85	7.0	1.9	1.3	2.2
160L1	15	20	88.0	0.86	7.0	2.0	1.2	2.2
160L2	18.5	25	89.5	0.86	7.0	2.0	1.2	2.2
180M	22	30	89.5	0.86	7.0	1.9	1.2	2.2
180L	30	40	90.5	0.87	7.0	1.9	1.2	2.2
200M	37	50	90.5	0.87	7.0	2.0	1.2	2.2
200L	45	60	91.5	0.87	7.0	2.0	1.1	2.2
225M	55	75	91.5	0.88	7.0	1.8	1.1	2.2
250S	75	100	92.0	0.88	6.7	2.0	0.9	2.2
250M	90	120	92.5	0.88	6.7	2.2	0.9	2.2
280S	110	150	92.5	0.88	6.7	1.7	0.9	2.2
280M	132	176	93.0	0.88	6.8	1.8	0.9	2.2
315S	160	215	93.0	0.88	6.8	1.4	0.95	2.0
315M1	(185)	247	93.5	0.88	6.8	1.4	0.83	2.0
315M2	200	267	93.8	0.88	6.8	1.4	0.83	2.0
315M3	(220)	300	94.0	0.88	6.8	1.4	0.83	2.0
315M4	250	335	94.3	0.88	6.8	1.2	0.83	2.0
355M1	-	-	-	-	-	-	-	-
355M2	(280)	375	94.3	0.89	6.5	1.2	0.71	1.8
355M3	315	420	94.3	0.90	6.5	1.0	0.71	1.8
355M4	-	-	-	-	-	-	-	-
355L1	355	475	94.5	0.90	6.5	1.0	0.71	1.8
355L2	-	-	-	-	-	-	-	-
6 Poles Synchronous Speed 1000 r/min 6极 同步转速 1000 r/min								
160M	7.5	10	85.0	0.79	6.5	2.0	1.3	2.0
160L1	11	15	86.5	0.78	6.5	2.0	1.2	2.0
160L2	-	-	-	-	-	-	-	-
180M	15	20	88.0	0.81	6.5	1.8	1.2	2.0
180L	18.5	25	88.5	0.83	6.5	1.8	1.2	2.0
200M	22	30	89.0	0.85	6.5	1.7	1.2	2.0
200L	30	40	89.5	0.85	6.5	1.7	1.2	2.0
225M	37	50	90.5	0.87	6.5	1.8	1.2	2.0
250S	45	60	91.0	0.86	6.5	1.8	1.1	2.0
250M	55	75	91.0	0.87	6.5	1.8	1.1	2.0
280S	75	100	91.5	0.87	6.5	1.8	0.9	2.0
280M	90	120	92.0	0.88	6.5	1.8	0.9	2.0
315S	110	150	93.0	0.87	6.5	1.3	0.95	1.8
315M1	132	176	93.5	0.87	6.5	1.3	0.95	1.8
315M2	160	215	93.8	0.87	6.5	1.3	0.95	1.8
315M3	-	-	-	-	-	-	-	-
315M4	-	-	-	-	-	-	-	-
355M1	(185)	247	94.3	0.87	6.0	1.1	0.83	1.8
355M2	200	267	94.0	0.87	6.0	1.1	0.83	1.8
355M3	(220)	300	94.0	0.88	6.0	1.1	0.83	1.8
355M4	250	335	94.3	0.88	6.0	1.1	0.83	1.8
355L1	(280)	375	94.3	0.88	6.0	1.1	0.71	1.8
355L2	-	-	-	-	-	-	-	-

三相感应电动机

TECHNICAL DATA 技术参数

额定电压: 380V 频率: 50Hz Rated Voltage: 380V Frequency: 50Hz

Type 型号	Rated Output 功率		Eff 效率 (%)	P.F. 功率因素 cosφ	堵转电流 额定电流 Ist/In	堵转转矩 额定转矩 Tst/Tn	最小转矩 Lmin/Tn	最大转矩 Tmax/Tn
	Kw	Hp						
8 Poles Synchronous Speed 750 r/min 8极 同步转速 750 r/min								
160M	5.5	7.5	83.5	0.73	6.0	2.0	1.2	2.0
160L1	7.5	10	85.0	0.73	6.0	2.0	1.2	2.0
160L2	-	-	-	-	-	-	-	-
180M	11	15	86.5	0.74	6.0	1.8	1.1	2.0
180L	15	20	87.5	0.76	6.0	1.8	1.1	2.0
200M	18.5	25	88.5	0.78	6.0	1.7	1.1	2.0
200L	22	30	89.0	0.78	6.0	1.8	1.1	2.0
225M	30	40	89.5	0.81	6.0	1.7	1.1	2.0
250S	37	50	90.0	0.80	6.0	1.6	1.1	2.0
250M	45	60	90.5	0.80	6.0	1.8	0.9	2.0
280S	55	75	91.5	0.80	6.0	1.8	0.9	2.0
280M	75	100	91.5	0.81	6.0	1.8	0.8	2.0
315S	90	120	92.2	0.81	6.0	1.3	0.83	1.8
315M1	110	150	92.8	0.81	6.0	1.3	0.83	1.8
315M2	132	176	93.3	0.81	6.0	1.3	0.83	1.8
315M3	-	-	-	-	-	-	-	-
315M4	-	-	-	-	-	-	-	-
355M1	-	-	-	-	-	-	-	-
355M2	160	215	93.5	0.81	5.5	1.1	0.83	1.8
355M3	(185)	247	93.5	0.81	5.5	1.1	0.83	1.8
355M4	200	267	93.5	0.81	5.5	1.1	0.83	1.8
355L1	(220)	300	94.0	0.81	5.5	1.1	0.83	1.8
355L2	250	335	94.0	0.79	5.5	1.1	0.83	1.8
10 Poles Synchronous Speed 600 r/min 10极 同步转速 600 r/min								
315S	55	75	91.5	0.74	5.5	1.2	0.71	1.8
315M1	75	100	92.0	0.75	5.5	1.2	0.71	1.8
315M2	90	120	92.0	0.76	5.5	1.2	0.71	1.8
315M3	-	-	-	-	-	-	-	-
315M4	-	-	-	-	-	-	-	-
355M1	-	-	-	-	-	-	-	-
355M2	110	150	92.5	0.78	5.5	1.0	0.71	1.8
355M3	132	176	92.8	0.79	5.5	1.0	0.71	1.8
355M4	-	-	-	-	-	-	-	-
355L1	160	215	92.8	0.79	5.5	1.0	0.71	1.8
355L2	(185)	247	93.0	0.79	5.5	1.0	0.71	1.8
12 Poles Synchronous Speed 500 r/min 12极 同步转速 500 r/min								
355M4	90	120	92.0	0.74	5.5	1.0	0.5	1.0
355L1	110	150	92.3	0.75	5.5	1.0	0.5	1.0
355L2	132	18	92.5	0.75	5.5	1.0	0.5	1.0

INSTALLATION SIZE 安装尺寸 (mm)

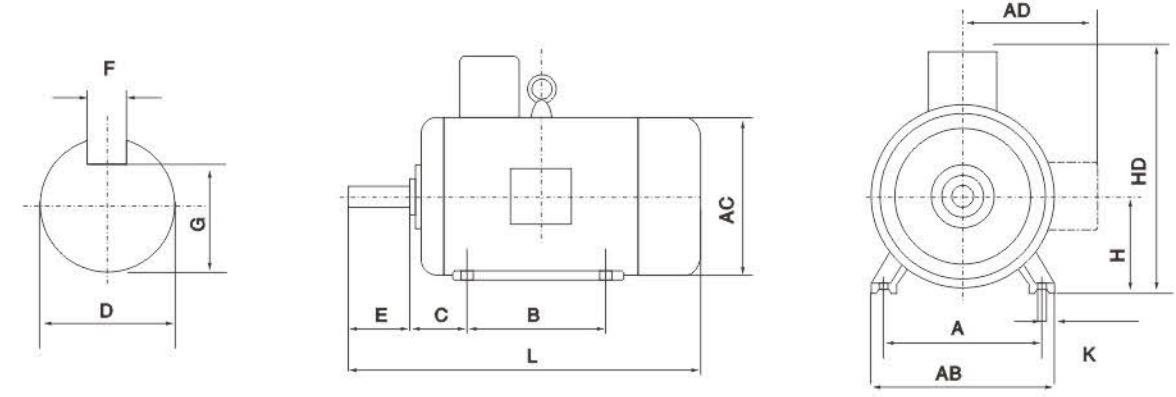

Type 型号	Poles 极数	Mounting dimensions(mm) 安装尺寸									Overall dimensions(mm) 外形尺寸				
		A	B	C	D	E	F	G	H	K	AB	AC	AD	HD	L
Y160M	2,4,6,8	245	210	108	48	110	14	42.5	160	14.5	330	380	290	290	676
Y160L			254												
Y180M	2,4,6,8	279	241	121	55	110	16	49	180	14.5	350	420	325	505	726
Y180L			279												
Y200M	2,4,6,8	318	267	133	60	140	18	53	200	18.5	400	465	350	570	820
Y200L			305												886
Y225M	2, 4,6,8	365	311	149	65	140	18	58	225	18.5	450	520	395	640	880
Y250S	2, 4,6,8														
Y250M	2, 4,6,8	406	349	168	75	140	18	58	250	24	510	550	410	710	930
Y280S	2, 4,6,8														960
Y280M	2, 4,6,8,10	457	419	190	80	170	22	71	280	24	570	610	485	1090	1140
Y315S	2, 4,6,8				1130										
Y315M	2, 4,6,8,10	508	457	216	70	170	25	81	315	28	630	792	586	928	1160
Y355M	2, 4,6,8,10				1240										
Y355L	2, 4,6,8,10	610	630	254	75	140	20	67.5	355	28	710	980	1620	1620	1550
	2, 4,6,8,10				1690										

三相感应电动机

ANP系列三相异步电动机采用全封闭式风机冷却。额定功率及安装尺寸符合GOST标准, 220v/380v(56-112), 380/660v(132-355)额定电压, 额定频率50Hz, F级绝缘, IP54/P5防护等级, C411冷却方式。该款电机高效、节能、低噪音、振动于、运行可靠, 广泛应用于各种机械驱动器中, 如泵、风机、输送机、搅拌机、农业机械、矿山机械等。

ANP series three-phase electrical motors are totally enclosed and fan-cooling. The power rating and installation size conform to GOST standard, 220v/380v(56-112), 380/660v(132-355) rated voltage with 50Hz rated frequency, F grade insulation, IP54/P5 degree of covering protection, C411 cooling method. With high efficiency, energy-saving, low noise, little vibration reliable running, it is widely used as drivers for various kind of machines, such as pumps, blower, conveyer, mixer, agriculture machinery and mine machinery etc.

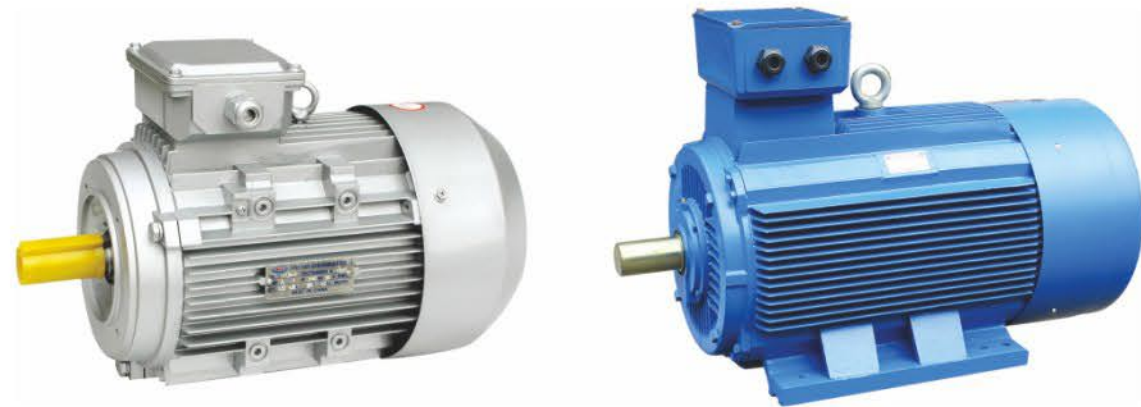

TECHNICAL DATA 技术参数

Model	PH,KBT	N,об./MNH	эффeктивнoсть	cosφ	IH A(U=380B)	In/IH	Mm/MH	Mn/MH	Macca,KT
	Rated Power KW	Rated Power 1/min	Efficiency %	Power factor	In A(U=380B)	Is/In	Tmax/Tn	Ts/Tn	Weight,Kg
2P=2,n=3000 o6,MNH									
AIP56A2	0.18	2700	65.7	0.77	0.55	5.3	2.2	2.2	4.7
AIP56B2	0.25	2720	68.0	0.78	0.73	5.3	2.2	2.2	5.1
AIP63A2	0.37	2730	69.7	0.81	1	5.7	2.2	2.2	5.5
AIP63B2	0.55	2770	72.7	0.82	1.4	5.7	2.3	2.2	6.4
AIP71A2	0.75	2820	74	0.83	1.9	6.1	2.3	2.2	8.5
AIP71B2	1.1	2790	77.6	0.83	2.7	6.7	2.3	2.2	9.6
AIP80A2	1.5	2830	78.1	0.84	3.6	7	2.3	2.2	15.5
AIP80B2	2.2	2840	80.6	0.85	5	7	2.3	2.2	19.5
AIP90L2	3.0	2845	83.4	0.86	6.5	7.2	2.3	2.2	25.4
AIP100S2	4.0	2870	83.7	0.88	8.4	7.5	2.3	2.2	33
AIP100L2	5.5	2870	84.8	0.89	11	7.5	2.3	2.2	38
AIP112M2	7.5	2880	85.4	0.88	15.2	7.2	2.4	2.2	49
AIP132M2	11	2900	87.4	0.9	21.8	7.2	2.3	2.2	83
AIP160S2	15	2925	88.4	0.88	30	7.1	2.4	2.2	120
AIP160M2	18.5	2925	89.3	0.89	36.3	7.1	2.4	2.2	140
AIP180S2	22	2940	89.8	0.9	42.7	7.2	2.5	2	170
AIP180M2	30	2940	90.7	0.9	56.9	7.3	2.5	2.1	203
AIP200M2	37	2940	91.2	0.89	71	7.1	2.4	2.1	247
AIP200L2	45	2945	91.8	0.89	84.9	7.1	2.4	2.1	255

TECHNICAL DATA 技术参数

Model	PH,KBT	N,об./MNH	эффeктивнoсть	cosφ	IH A(U=380B)	In/IH	Mm/MH	Mn/MH	Macca,KT
	Rated Power KW	Rated Power 1/min	Efficiency %	Power factor	In A(U=380B)	Is/In	Tmax/Tn	Ts/Tn	Weight,Kg
2P=2,n=3000 o6,MNH									
AIP225M2	55	2960	92	0.9	103	7.1	2.4	2.1	325
AIP250S2	75	2970	92.6	0.9	139	6.9	2.6	2	450
AIP250M2	90	2970	92.5	0.9	167	6.4	2.5	2	530
AIP280S2	110	2970	93.4	0.91	201	6.7	2.3	1.9	650
AIP280M2	132	2975	93.5	0.91	240	6.4	2.4	1.9	700
AIP315S2	160	2975	94.4	0.91	289	6.7	2.3	1.9	1170
AIP315M2	200	2975	94.7	0.92	358	6.6	2.3	1.9	1460
AIP355S2	250	2980	95.4	0.92	433	6.9	2.2	1.7	1930
AIP355M2	315	2980	95.6	0.92	548	6.9	2.2	1.7	2300
2P=4,n=1500 o6,MNH									
AIP56A4	0.12	1325	56.5	0.66	0.5	4.6	2.2	2.1	4.5
AIP56B4	0.18	1325	61.2	0.68	0.7	4.9	2.2	2.1	5.1
AIP63A4	0.25	1325	64.5	0.73	0.82	5.1	2.2	2.1	5.6
AIP63B4	0.37	1325	66.3	0.76	1.12	5.1	2.2	2.1	6.4
AIP71A4	0.55	1350	70	0.73	1.75	5.4	2.3	2.2	8.2
AIP71B4	0.75	1360	71.3	0.77	2.2	5.7	2.3	2.2	9.6
AIP80A4	1.1	1375	74.5	0.76	3.04	5.8	2.3	2.3	16
AIP80B4	1.5	1390	77.5	0.78	3.95	6.2	2.3	2.3	19.5
AIP90L4	2.2	1400	80	0.81	5.3	6.8	2.3	2.3	25
AIP100S4	3	1420	81.4	0.82	7.2	7	2.3	2.3	34
AIP100L4	4	1420	82.8	0.81	9.5	7	2.3	2.3	37
AIP112M4	5.5	1430	84.1	0.82	12.3	6.6	2.3	2.3	55
AIP132S4	7.5	1440	86	0.84	16.1	6.7	2.3	2.2	76
AIP132M4	11	1450	87.1	0.84	23.1	6.8	2.3	2.2	88
AIP160S4	15	1455	88.7	0.85	30.8	6.8	2.3	2.2	138
AIP160M4	18.5	1455	89.8	0.86	37.8	6.8	2.3	2.2	142
AIP180S4	22	1465	90.6	0.86	44.4	7	2.4	2.1	177
AIP180M4	30	1465	91.2	0.86	59.6	6.8	2.3	2.1	190
AIP200M4	37	1470	92	0.87	3.1	7	2.3	2.2	247
AIP200L4	45	1465	92.3	0.87	88.4	6.9	2.4	2.2	260
AIP225M4	55	1480	92.4	0.87	106	6.7	2.3	2.2	326
AIP250S4	75	1475	92.9	0.86	146	6.9	2.3	2.2	477
AIP250M4	90	1475	93.3	0.87	170	6.4	2.4	2.2	485
AIP280S4	110	1480	93.8	0.88	207	6.6	2.2	2.1	731
AIP280M4	132	1480	93.8	0.88	244	6.7	2.3	2.3	710
AIP315S4	160	1480	94.8	0.89	297	6.8	2.4	2.3	1053
AIP315M4	200	1480	95	0.89	369	6.4	2.4	2.2	1243
AIP355S4	250	1490	95.4	0.9	443	6.7	2.4	2.1	1745
AIP355M4	315	1490	95.6	0.9	558	6.7	2.4	2.1	1957
2P=6,n=1000 o6,MNH									
AIP63A6	0.18	860	55.5	0.64	0.8	4.1	2	1.9	6.4
AIP63B6	0.25	860	58.3	0.65	1.1	4	2	1.9	7.2
AIP71A6	0.37	895	62.8	0.68	1.33	4.7	2	1.9	8.8
AIP71B6	0.55	895	65.7	0.7	1.9	4.7	2	1.9	9.8
AIP80MA6	0.75	910	69	0.72	2.29	5.3	2.1	2	16.7
AIP80MB6	1.1	910	72.1	0.74	3.18	5.3	2.1	2	20
AIP90L6	1.5	920	76	0.74	4.2	6	2.1	2	25
AIP100L6	2.2	930	77.1	0.76	5.9	6.3	2.1	2	38
AIP112MA6	3	935	80.1	0.76	7.9	5.7	2.2	2.1	46
AIP112MB6	4	935	80.7	0.77	10.3	5.7	2.1	2.1	50
AIP132S6	5.5	955	82.8	0.78	13.4	6.3	2.1	2.1	75
AIP132M6	7.5	960	84.1	0.8	17.2	6.2	2.2	2.1	87

三相感应电动机

Model	PH,KBT	N,об./MNH	эффективность	cosφ	IHA(U=380B)	In/IH	Mm/MH	Mn/MH	Масса,KT
	Rated Power KW	Rated Power 1/min	Efficiency %	Power factor	In A(U=380B)	Is/In	Tmax/Tn	Ts/Tn	Weight,Kg
2P=6,n=1000 о6,MNH									
AIP160S6	11	965	86.8	0.79	24.6	6.3	2.2	2	141
AIP160M6	15	965	88.2	0.81	33	6.5	2.2	2	155
AIP180M6	18.5	970	88.9	0.82	39	6.6	2.1	2.1	200
AIP200M6	22	975	89.7	0.83	45.2	6.3	2.2	2.1	233
AIP200L6	30	975	89.8	0.84	61.8	6.5	2.2	2.1	250
AIP225M6	37	980	91.3	0.85	73.5	6.6	2.1	2.1	360
AIP250S6	45	980	92	0.85	90.1	6.7	2.2	2.1	465
AIP250M6	55	985	92.4	0.84	110	6.8	2.3	2.2	520
AIP280S6	75	985	93	0.85	150	6.6	2.1	2	800
AIP280M6	90	985	92.9	0.85	177	6.6	2.2	2.2	800
AIP315S6	110	985	94.2	0.86	207	6.3	2.2	2	1045
AIP315M6	132	985	94.4	0.87	244	6.1	2.2	2	1103
AIP355S6	160	990	94.7	0.87	292	6.6	2.2	1.9	1748
AIP355M6	200	990	94.7	0.87	364	6.7	2.2	1.9	1934
AIP355MB6	250	990	95.2	0.88	451	6.6	2.5	1.9	2050
2P=8,n=750 о6,MNH									
AIP71B8	0.25	655	54.5	0.6	1.17	3.7	1.9	1.8	9.1
AIP80MA8	0.37	675	60.1	0.62	1.5	4.3	1.9	1.8	18
AIP80MB8	0.55	675	62.9	0.62	2.18	4	2	1.8	18.9
AIP90LA8	0.75	685	72.4	0.7	2.33	4	2	1.9	30
AIP100L8	1.1	685	73	0.69	3.27	4	2	1.9	26
AIP100L4	1.5	690	73.5	0.72	4.5	4.7	2	1.9	38
AIP112MA8	2.2	700	75.6	0.71	6.4	4.9	2.1	2	46
AIP112MB8	3	700	76.9	0.71	8.6	5	2.1	2	53
AIP132S8	4	715	81.9	0.78	10.8	5.6	2.1	2.1	82
AIP132M8	5.5	715	80.9	0.74	14.7	5.6	2.1	2.1	90
AIP160S8	7.5	720	85.2	0.74	19.2	5.8	2.1	2	148
AIP160M8	11	720	86.4	0.76	27.3	5.8	2.1	2	155
AIP180M8	15	725	87.6	0.78	34.5	6.2	2	2	210
AIP200M8	18.5	730	89	0.78	41.6	6.2	2.1	1.9	250
AIP200L8	22	730	89.6	0.78	49.4	6.2	2.1	2	260
AIP225M8	30	735	90.6	0.78	65.3	6.5	2.1	2	360
AIP250S8	37	735	90.5	0.77	82.1	6.2	2.3	2.1	465
AIP250M8	45	735	91.5	0.77	99.1	6.2	2.3	2.1	520
AIP280S8	55	735	92	0.8	121	6	2	1.9	725
AIP280M8	75	740	92	0.81	154	5.8	2.1	1.9	800
AIP315S8	90	740	93.8	0.82	178	6.2	2.3	2	1160
AIP315M8	110	740	94	0.82	217	6.1	2.2	2	1175
AIP355S8	132	740	93.9	0.82	261	6.3	2.2	1.7	2000
AIP355M8	160	740	94.3	0.82	306	6.3	2.2	1.7	2150
AIP355MB8	200	740	94.7	0.83	386	6.5	2.5	1.8	2250
2P=10,n=600 о6,MNH									
AIP250S10	22	585	86	0.7	55.5	6	2	1.6	475
AIP250M10	30	585	88.5	0.7	73.6	6	2	1.6	535
AIP280S10	37	590	89	0.7	90.2	6	2	1.6	720
AIP280M10	45	590	91	0.72	110	6	2	1.6	835
AIP315S10	55	590	92	0.75	121	6.2	2	1.5	1150
AIP315M10	75	590	92.5	0.76	162	6.2	2	1.5	1220
AIP355S10	90	590	92.8	0.77	192	6.1	2	1.4	2080
AIP355MA10	110	590	93.2	0.78	230	6	2	1.3	1800
AIP355MB10	132	590	93.5	0.78	275	6	2	1.3	2500
AIP355M10	160	590	93.5	0.78	333	6	2	1.3	2500

INSTALLATION SIZE 安装尺寸 (mm)

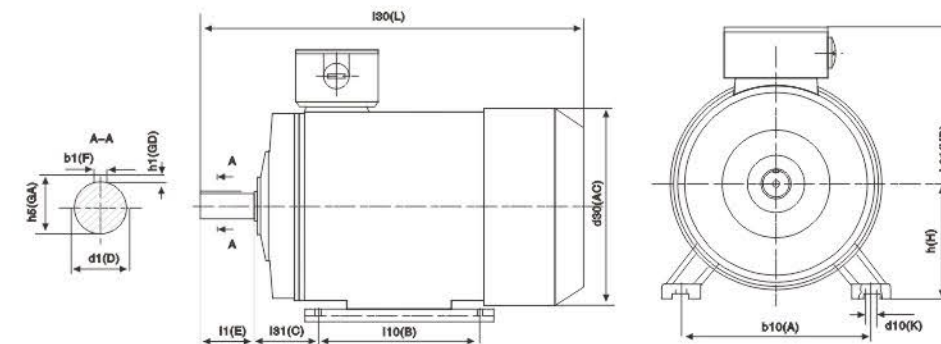

Type 型号	Poles 极数	Overall dimensions(mm) 外形尺寸					Mounting dimensions 安装尺寸 (mm)									
		130 L	h31 HD	d30 AC	b10 A	b11 AB	I10 B	I11 BB	I31 C	D1 D	I1 E	b1 F	h5 GA	h1 GD	h H	d10 K
AIP56A	2,4	216	165	120	90	113	71	90	36	11	23	4	12.5	4	56	5.8
AIP56N		216	165	120	90	113	71	90	36	11	23	4	12.5	4	56	5.8
AIP63A	2,4,6	250	180	136	100	124	80	102	40	14	30	5	16	4	63	5.8
AIP63B		250	180	136	100	124	80	102	40	14	30	5	16	4	63	5.8
AIP71A	2,4,6	295	205	155	112	155	90	120	45	19	40	5	21.5	5	71	7
AIP71B	2,4,6,8	295	205	155	112	155	90	120	45	19	40	5	21.5	5	71	7
AIP80A	2,4,6,8	320	230	176	125	160	100	130	50	22	50	6	24.5	6	80	10
AIP80B		350	230	176	125	160	100	140	50	22	50	6	24.5	6	80	10
AIP90LA	2,4,6,8	380	245	185	140	176	125	170	56	24	50	8	27	7	90	10
AIP90LB	8	380	245	185	140	176	125	170	56	24	50	8	27	7	90	10
AIP100S	2,4	415	275	215	160	205	112	180	63	28	60	8	31	7	100	12
AIP100L	2,4,6,8	420	275	215	160	205	140	185	63	28	60	8	31	7	100	12
AIP112MA	2,4,6,8	400	300	240	190	240	140	223	70	32	80	10	35	8	112	12
AIP112MB	6,8	490	302	240	190	240	140	223	70	32	80	10	35	8	112	12
AIP132S	4,6,8	615	355	283	216	275	140	223	89	38	80	10	41	8	132	12
AIP132M	2,4,6,8	615	355	283	216	275	178	223	89	38	80	10	41	8	132	12
AIP160S	2	670	435	330	254	320	178	314	108	42	110	12	45	8	160	15
AIP160	4,6,8	670	435	330	254	320	178	314	108	42	110	14	51.5	9	160	15
AIP160	2	670	435	330	254	320	210	314	108	42	110	12	45	8	160	15
AIP160	4,6,8	670	435	330	254	320	210	314	108	42	110	14	51.5	9	160	15
AIP180S	2	700	455	380	279	355	203	343	121	48	110	14	51.5	9	180	15
AIP180	4	700	455	380	279	355	203	343	121	55	110	16	59	10	180	15
AIP180M	2	769	455	380	279	355	241	355	121	48	110	14	51.5	9	180	15
AIP180M	4,6,8	769	455	380	279	355	241	355	121	55	110	16	59	10	180	15
AIP200M	2	852	505	420	318	395	267	377	133	55	110	16	59	10	200	19
AIP200M	4,6,8	852	505	420	318	395	267	377	133	60	110	18	64	11	200	19
AIP200L	2	887	505	420	318	395	305	377	133	55	110	16	59	10	200	19
AIP200L	4,6,8	887	505	420	318	395	305	377	133	60	140	18	64	11	200	19
AIP225M	2	855	560	470	356	435	311	394	149	55	110	16	59	10	225	19
AIP225M	4,6,8	855	560	470	356	435	311	394	149	65	140	18	69	11	225	19
AIP250S	2	981	635	510	406	490	311	445	168	65	140	18	69	11	250	24
AIP250S	4,6,8,10	981	635	510	406	490	311	445	168	75	140	20	79.5	12	250	24
AIP250M	2	1031	615	510	406	490	349	459	168	65	140	18	69	11	250	24
AIP250M	4,6,8,10	1031	615	510	406	490	349	459	168	75	140	20	79.5	12	250	24
AIP280S	2	1146	698	580	457	550	368	540	190	70	140	20	74.5	12	280	24
AIP280S	4,6,8,10	1146	698	580	457	550	368	540	190	80	170	22	85	14	280	24
AIP280M	2	1197	680	580	457	550	419	540	190	70	140	20	74.5	12	280	24
AIP280M	4,6,8,10	1197	680	580	457	550	419	540	190	80	170	22	85	14	280	24
AIP315S	2	1318	870	650	508	640	406	680	216	75	140	20	79.5	12	315	28
AIP315S	4,6,8,10	1318	870	650	508	640	406	680	216	90	170	25	95	14	315	28
AIP315M	2	1325	870	650	508	640	457	680	216	75	140	20	79.5	12	315	28
AIP315M	4,6,8,10,12	1325	870	650	508	640	457	680	216	90	170	25	95	14	315	28
AIP355S	2	1556	1010	735	610	735	500	775	254	85	170	22	90	14	355	28
AIP355S	4,6,8,10,12	1570	1010	735	610	735	500	775	254	100	210	28	106	16	355	28
AIP355M	2	1556	1010	735	610	735	560	775	254	85	170	22	90	14	355	28
AIP355M	4,6,8,10,12	1570	1010	735	610	735	560	775	254	100	210	28	106	16	355	28

三相调速调校电磁电机

YCT系列电磁调速电机是由拖动电机、电磁转差离合器和控制器三部分组成,通常和JD型或者ZTK型控制器配套使用。可用于恒转矩负载场合,特别适宜在递减转矩负载中使用(例如离心式水泵和风机),广泛应用于各类装配流水线、输送设备、注塑机、印刷机、水泵、风机、回转炉、卷板机、拉线机等工业设备。

YCT series electromagnetic speed regulating motor is composed of three parts: drive motor, electromagnetic slip clutch and controller. It is usually used with JD or ZTK controller. It can be used in constant torque load occasion, especially in decreasing torque load (such as centrifugal pump and fan). It is widely used in various assembly lines, conveying equipment, injection moulding machine, printing machine, water pump, fan, rotary furnace, winder, wire drawing machine and other industrial equipment.

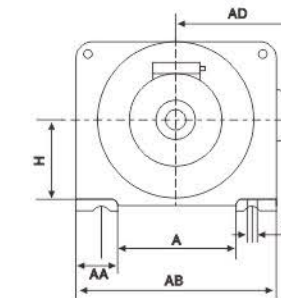
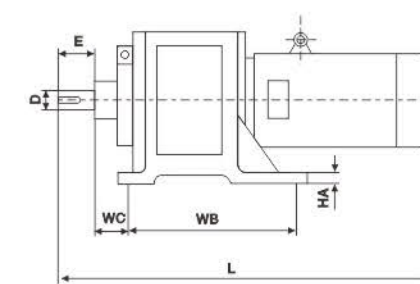
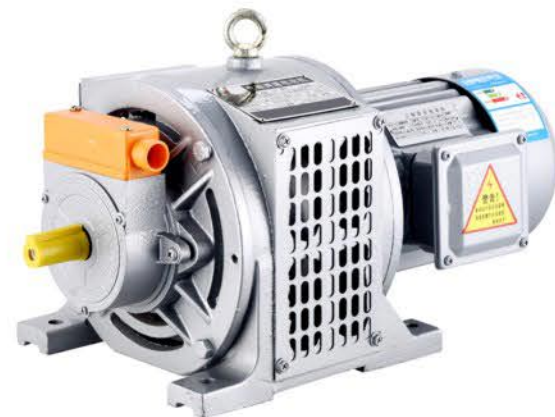

Mounting mode for all the series

The mounting arrangements of the motors comply with IEC34-7 recommendation. There are four basic arrangements as shown the following tables and figures.

所有系列的电机安装模式都符合IEC34-7标准。如下表和图所示为四种常规电机安装方式。

Fundamental Arrangement 具体安装方式	B3					
Mounting Arrangement 安装方式	B3	B6	B7	B8	V5	V6
Diagram 示意图						
Range of Manufacture (frame size) 尺寸范围	63-335		63-160			
Fundamental Arrangement 具体安装方式	B5			B35		
Mounting Arrangement 安装方式	B5	V1	V3	B35	V15	V36
Diagram 示意图						
Range of Manufacture (frame size) 尺寸范围	63-280	63-335	63-160	63-335	63-160	63-160
Fundamental Arrangement 具体安装方式	B14					
Mounting Arrangement 安装方式	B14	B34	V18	V58	V19	V69
Diagram 示意图						
Range of Manufacture (frame size) 尺寸范围	63-132					

Base no 型号		Dimension 外形尺寸 (mm)										Installation size(mm) 安装尺寸					Weight 重量 (kg)
		A	A/2	WB	WC	D	E	F	G	H	K	AB	AC	AD	HD	L	
90	-4A	160	80	178	40	18	40	6	14.5	90	10	190	200	130	220	480	34
	-4B																36
112	-4A	190	95	210	40	19	40	6	15.5	112	12	240	260	150	280	520	50
	-4B																53
132	-4A	216	708	241	40	24	50	8	20	132	12	285	310	165	330	570	75
	-4B																77
160	-4A	254	127	267	45	28	60	8	24	160	15	320	350	185	385	665	112
	-4B																117
180	-4A	279	139.5	305	45	28	60	8	24	180	15	365	385	195	430	700	157
	-4B																157
200	-4A	318	159	356	50	38	80	10	33	200	19	410	430	235	485	820	224
	-4B																244
225	-4A	356	178	406	56	42	110	12	37	225	19	465	485	270	545	980	390
	-4B																420
250	-4A	406	203	457	63	48	110	14	42.5	250	24	520	540	295	595	1130	460
	-4B																502
260	-4A	457	228.5	508	70	55	110	16	49	280	24	575	595	320	665	1280	632
	-4B																632
315	-4A	508	254	560	89	60	140	18	53	315	28	645	670	345	770	1400	810
	-4B																850
355	-4A	610	305	630	108	65	140	18	58					390		1550	1510
	-4B					75	140	20	67.5	355	28	755	780	420	890	1630	1655
	-4C															1680	1700
400	-4A	630	315	710	108	80	170	22	71	400	32	800	820	500	820	1980	2050
	-4B															2030	2150
	-4C																2210

TECHNICAL DATA 技术参数

Type 型号		Rated output 功率		Rated torque(N.m) 额定转矩	Adjustable Range (r/min)	Variable Rate Of Speed Less Than %
		KW	Hp			
90	-4A	0.25	1/3	1.6	1200-120	2.5
	-4B	0.37	1/2	2.3		
112	-4A	0.55	3/4	3.6	1230-125	
	-4B	0.75	1	4.9		
132	-4A	1.1	1.2	7.1	1250-120	
	-4B	1.5	2	9.7		
160	-4A	2.2	3	14.1	1320-132	
	-4B	3	4	19.2		
180	-4A	4	5.5	25.2	1340-440	
	-4B	5.5	7.5	36.1		
200	-4A	7.5	10	47.7	1340-600	
	-4B	11	15	69		
225	-4A	15	20	94	1350-650	
	-4B	18.5	25	110		
250	-4A	22	30	137		
	-4B	30	40	189		
280	-4A	37	50	232		
	-4B	45	60	282		
315	-4A	55	75	344		
	-4B	75	100	469		
355	-4A	90	125	564		
	-4B	110	150	690		
400	-4A	132	180	827		
	-4B	160	220	1000		

防爆三相异步电动机

PRODUCT OVERVIEW 产品概述

YB2系列隔爆型三相异步电动机是在YB、YB2系列电动机的基础上结合当前国内外电磁结构、工艺、材料等方面的新技术而开发研制成功的新产品，具有高效节能、温升裕度大、寿命长、性能好、噪音低、隔爆结构先进、可靠性高、使用维护方便等优点。

YB2防爆电机用作煤矿井下（非采掘工作面）固定式设备或工厂IIB级，温度组别为T1—T4组的可燃性气体或蒸气与空气形成的爆炸性混合物的场所内的机械设备的驱动电机，主要用于煤矿、石油天然、石油化工和化学工业。此外，在纺织、冶金、城市煤气、交通、粮油加工、造纸、医药等部门也被广泛应用。防爆电机作为主要的动力设备，通常用于驱动泵、风机、压缩机、输送机和其他传动机械。

YB2 series explosion-proof three-phase asynchronous motor is a new kind of product developed on the basis of YB and YB2 series motors adopts the latest technology in the world such as electromagnetic structure, craft and materials etc. It has the advantages of high efficiency, energy saving, large temperature rise margin, long life, good performance, low noise, advanced flameproof structure, high reliability, convenient use and maintenance.

YB2 explosion-proof motor is used as fixed equipment for underground coal mine (non-mining work). It also used as drive device that applied to the place which composed of explosive mixture(combined air with factory IIB,T1-T4 temperature group flammable gas/steam. It is mainly used in coal mine, petroleum natural, petrochemical and chemical industries. In addition, it has been widely used in textile, metallurgy, city gas, transportation, grain and oil processing, paper making, medicine and other departments. As the main power equipment, explosion-proof motor is usually used to drive pumps, fans, compressors, conveyors and other transmission machinery.



TECHNICAL DATA 技术参数

额定电压：380V 频率：50Hz Rated Voltage:380V Frequency:50Hz

Type 型号	Rated Output 功率		Eff 效率 (%)	P.F. 功率因素 cosφ	堵转电流 额定电流 Ist/In	堵转转矩 额定转矩 Tst/Tn	最大转矩 额定转矩 Tmax/Tn	Weight 重量 (Kg)
	Kw	Hp						
2 Poles Synchronous Speed 3000 r/min 2极 同步转速 3000 r/min								
63M1	0.18	0.25	65.0	0.80	5.0	2.2	2.3	14
63M2	0.25	0.35	68.0	0.81	5.0	2.2	2.3	15
71M1	0.37	0.5	69.0	0.81	5.5	2.2	2.3	17
71M2	0.55	0.75	74.0	0.82	5.5	2.2	2.3	18
80M1	0.75	1	77.5	0.83	6.0	2.2	2.3	25
80M2	1.1	1.5	82.8	0.83	6.0	2.2	2.3	27
90S	1.5	2	84.1	0.84	7.0	2.2	2.3	32
90L	2.2	3	85.6	0.85	7.0	2.2	2.3	35
100L2	3	4	86.7	0.87	7.0	2.2	2.3	45
112M	4	5.5	87.6	0.88	7.0	2.2	2.3	57
132S1	5.5	7.5	88.6	0.88	7.5	2.2	2.3	80
132S2	7.5	10	89.5	0.89	7.5	2.2	2.4	84
160M1	11	15	90.5	0.89	7.5	2.2	2.4	130
160M2	15	20	91.3	0.89	7.5	2.2	2.4	139
160L	18.5	25	91.8	0.89	7.5	2.2	2.4	158
180M	22	30	92.2	0.89	7.5	2.0	2.3	183
200L1	30	40	92.9	0.89	7.5	2.0	2.4	256
200L2	37	50	93.9	0.89	7.5	2.0	2.4	272
225M	45	60	93.7	0.89	7.5	2.0	2.3	353
250M	55	75	94.0	0.89	7.5	2.1	2.3	439
280S	75	100	94.6	0.89	7.5	2.0	2.3	558
280M	90	120	95.0	0.90	7.5	2.1	2.3	598
315S	110	150	95.0	0.90	7.0	1.8	2.3	980
315M	132	175	95.4	0.90	7.0	1.8	2.3	1060
315L1	160	215	95.4	0.90	7.0	1.8	2.3	1120
315L2	200	270	95.4	0.90	7.0	1.8	2.3	1180
355S1	185	250	95.4	0.90	7.0	1.8	2.3	1640
355S2	200	270	95.4	0.90	7.0	1.8	2.4	1640
355M1	220	295	96.0	0.92	7.0	1.6	2.4	1850
355M2	250	335	96.0	0.92	7.0	1.6	2.4	1900
355L1	280	375	96.0	0.92	7.0	1.6	2.4	2010
355L2	315	420	96.3	0.93	7.0	1.6	2.4	2140

防爆三相感应电动机

TECHNICAL DATA 技术参数

额定电压：380V 频率：50Hz Rated Voltage:380V Frequency:50Hz

Type 型号	Rated Output 功率		Eff 效率 (%)	P.F. 功率因素 cosφ	堵转电流 额定电流 Ist/In	堵转转矩 额定转矩 Tst/Tn	最大转矩 额定转矩 Tmax/Tn	Weight 重量 (Kg)
	Kw	Hp						
4 Poles Synchronous Speed 1500 r/min 2极 同步转速 1500 r/min								
63M1	0.12	0.15	58.0	0.72	4.0	2.0	2.2	14
63M2	0.18	0.25	63.0	0.73	4.0	2.0	2.2	15
71M1	0.25	0.35	66.0	0.74	4.0	2.0	2.2	16
71M2	0.37	0.5	69.0	0.75	4.0	2.0	2.2	17
80M1	0.55	0.75	71.0	0.75	5.0	2.4	2.3	24
80M2	0.75	1	73.0	0.77	5.0	2.4	2.3	26
90S	1.1	1.5	75.0	0.77	6.0	2.3	2.3	31
90L	1.5	2	78.0	0.79	6.0	2.3	2.3	35
100L1	2.2	3	80.0	0.81	6.0	2.3	2.4	43
100L2	3	4	82.0	0.82	6.0	2.3	2.4	47
112M	4	5.5	84.0	0.82	6.0	2.3	2.4	61
132S	5.5	7.5	86.0	0.84	7.0	2.3	2.4	80
132M	7.5	10	87.0	0.85	7.0	2.3	2.4	92
160M	11	15	88.0	0.85	7.0	2.2	2.4	134
160L	15	20	89.0	0.85	7.0	2.2	2.4	156
180M	18.5	25	90.5	0.85	7.0	2.2	2.3	197
180L	22	30	91.2	0.85	7.0	2.2	2.3	210
200L	30	40	92.0	0.86	7.2	2.2	2.4	267
225S	37	50	92.5	0.87	7.2	2.2	2.4	335
225M	45	60	92.8	0.87	7.2	2.2	2.4	368
250M	55	75	93.0	0.87	7.2	2.2	2.4	453
280S	75	100	93.8	0.87	7.2	2.2	2.4	595
280M	90	120	94.2	0.87	7.2	2.2	2.4	662
315S	110	150	94.5	0.89	7.2	2.1	2.4	1020
315M	132	175	94.8	0.89	7.0	2.1	2.4	1110
315L1	160	215	95.0	0.90	7.0	2.1	2.4	1180
315L2	200	270	95.2	0.90	7.0	2.1	2.3	1280
355S1	185	250	95.0	0.90	7.0	2.1	2.4	1650
355S2	200	270	95.2	0.90	7.0	2.1	2.3	1680
355M1	220	295	95.2	0.90	7.0	2.1	2.4	1870
355M2	250	335	95.5	0.90	7.0	2.1	2.4	1870
355L1	280	375	95.5	0.90	7.0	2.1	2.4	2050
355L2	315	420	95.6	0.90	7.0	2.1	2.4	2050

TECHNICAL DATA 技术参数

额定电压：380V 频率：50Hz Rated Voltage:380V Frequency:50Hz

Type 型号	Rated Output 功率		Eff 效率 (%)	P.F. 功率因素 cosφ	堵转电流 额定电流 Ist/In	堵转转矩 额定转矩 Tst/Tn	最大转矩 额定转矩 Tmax/Tn	Weight 重量 (Kg)
	Kw	Hp						
6 Poles Synchronous Speed 1000 r/min 6极 同步转速 1000 r/min								
71M1	0.18	0.25	62.0	0.66	4.0	1.9	2.1	17
71M2	0.25	0.35	63.0	0.68	4.0	1.9	2.1	18
80M1	0.37	0.5	63.0	0.70	4.0	1.9	2.1	25
80M2	0.55	0.75	66.0	0.72	4.0	1.9	2.1	27
90S	0.75	1	69.0	0.72	4.0	2.1	2.1	31
90L	1.1	1.5	73.0	0.73	5.0	2.1	2.1	34
100L	1.5	2	76.0	0.76	5.0	2.1	2.1	43
112M	2.2	3	79.0	0.76	5.0	2.1	2.1	57
132S	3	4	81.0	0.77	6.0	2.1	2.4	76
132M1	4	5.5	83.0	0.78	6.0	2.1	2.4	85
132M2	5.5	7.5	85.0	0.78	6.5	2.1	2.4	93
160M	7.5	10	86.0	0.79	6.5	2.1	2.4	129
160L	11	15	87.5	0.79	6.5	2.1	2.4	154
180L	15	20	89.0	0.81	7.0	2.1	2.1	200
200L1	18.5	25	90.0	0.83	7.0	2.2	2.4	248
200L2	22	30	90.0	0.83	7.0	2.2	2.4	257
225M	30	40	92.0	0.86	7.0	2.1	2.4	347
250M	37	50	92.0	0.86	7.0	2.1	2.4	426
280S	45	60	92.5	0.86	7.0	2.1	2.4	550
280M	55	75	92.8	0.86	7.0	2.1	2.3	598
315S	75	100	93.5	0.86	7.0	2.0	2.2	950
315M	90	120	94.8	0.86	7.0	2.0	2.2	1060
315L1	110	150	94.0	0.86	7.0	2.0	2.2	1150
315L2	132	175	94.2	0.87	7.0	2.0	2.2	1220
355S	160	215	94.5	0.88	7.0	2.0	2.2	1800
355M1	185	250	94.5	0.88	7.0	2.0	2.2	1980
355M2	200	270	94.7	0.88	7.0	2.0	2.2	2040
355L1	220	295	94.7	0.88	7.0	2.0	2.2	2150
355L2	250	335	95.0	0.88	7.0	2.0	2.2	2200

防爆三相感应电动机

TECHNICAL DATA 技术参数

额定电压：380V 频率：50Hz Rated Voltage:380V Frequency:50Hz

Type 型号	Rated Output 功率		Eff 效率 (%)	P.F. 功率因素 cosφ	堵转电流 额定电流 I _{st} /I _n	堵转转矩 额定转矩 T _{st} /T _n	最大转矩 额定转矩 T _{max} /T _n	Weight 重量 (Kg)
	Kw	Hp						
8 Poles Synchronous Speed 750 r/min 8极 同步转速 750 r/min								
80M1	0.18	0.25	52.0	0.61	3.3	1.8	1.9	26
80M2	0.25	0.35	55.0	0.61	3.3	1.8	1.9	27
90S	0.37	0.5	63.0	0.62	4.0	1.8	2.0	32
90L	0.55	0.75	64.0	0.63	4.0	1.8	2.0	35
100L1	0.75	1	71.0	0.68	4.0	1.8	2.0	41
100L2	1.1	1.5	73.0	0.69	4.0	1.8	2.0	43
112M	1.5	2	75.0	0.69	4.0	1.8	2.0	56
132S	2.2	3	79.0	0.73	5.5	1.8	2.2	76
132M	3	4	81.0	0.73	5.5	1.9	2.2	85
160M1	4	5.5	81.0	0.73	6.0	1.9	2.2	116
160M2	5.5	7.5	83.0	0.75	6.0	1.9	2.2	127
160L	7.5	10	85.0	0.76	6.0	1.9	2.2	151
180L	11	15	87.0	0.76	6.0	1.9	2.2	198
200L	15	20	89.0	0.76	6.5	2.0	2.2	256
225S	18.5	25	90.0	0.78	6.5	2.0	2.2	322
225M	22	30	90.5	0.78	6.5	2.0	2.2	349
250M	30	40	91.0	0.79	6.5	1.9	2.0	431
280S	37	50	91.5	0.79	6.0	1.8	2.0	556
280M	45	60	92.0	0.79	6.0	1.8	2.0	613
315S	55	75	92.8	0.81	6.5	1.9	2.2	930
315M	75	100	93.0	0.81	6.5	1.9	2.2	1090
315L1	90	120	93.8	0.82	6.5	1.9	2.2	1180
315L2	110	150	94.0	0.82	6.5	1.9	2.2	1270
355S	132	175	94.2	0.82	6.5	2.0	2.2	1800
355M	160	215	94.6	0.82	6.5	2.0	2.2	1980
355L1	185	250	94.6	0.82	6.5	2.0	2.2	2150
355L2	200	270	94.8	0.83	6.5	2.0	2.2	2200
10 Poles Synchronous Speed 600 r/min 10极 同步转速 600 r/min								
315S	45	60	92.0	0.75	6.0	1.5	2.1	890
315M	55	75	92.0	0.75	6.0	1.5	2.1	1000
315L1	75	100	92.5	0.76	6.0	1.5	2.1	1120
315L2	90	120	93.0	0.77	6.0	1.5	2.1	1190
355S	90	120	93.0	0.77	6.0	1.5	2.1	1715
355M1	110	150	93.2	0.78	6.0	1.3	2.1	1890
355M2	132	175	93.5	0.78	5.5	1.3	2.1	2020
355L1	160	215	93.6	0.78	5.5	1.3	2.1	2240
355L2	185	250	93.6	0.78	5.5	1.3	2.1	2365
355L3	200	270	93.6	0.79	5.5	1.3	2.1	2445

INSTALLATION SIZE 安装尺寸 (mm)

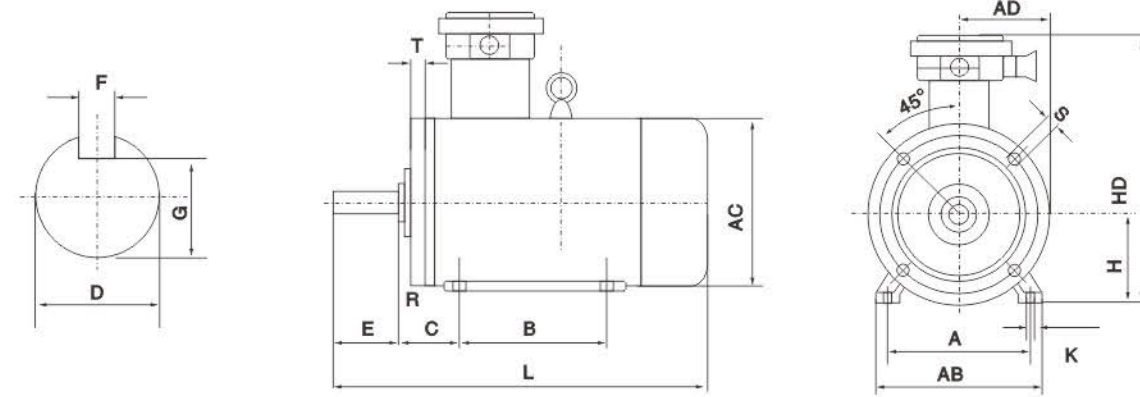

Type 型号	Poles 极数	Mounting dimensions 安装尺寸 (mm)										Overall dimensions(mm) 外形尺寸						
		A	B	C	D	E	F	G	H	K	R	S	T	AB	AC	AD	HD	L
63M	2,4	100	80	40	11	23	4	8.5	63	7	-	-	130	150	165	230	270	
71M	2,4,6	112	90	45	14	30	5	11	71	10	-	-	140	155	165	240	300	
80M	2,4,6,8	125	100	50	19	40	6	15.5	80	10	12	15	165	165	180	320	330	
90S		140		56	24	50	8	20	90				180	180		180	180	360
90L			125	63	28	60		24	100	200	205	200	450	510				
100L		160	70				80								10	33	132	400
112M		190	140	70	60	112	12	420	460									
132S		216	178	89	38	80	10	33	132	15	19	15	4	280	270	200	450	550
132M																		
160M		254	254	121	48	14	42.5	180	355	360	550	750						
160L		279	241	121	48	110	14	42.5	180	15	19	5	4	390	400	250	645	805
180M																		
180L	318	305	133	55	60	140	53	225	19	0	19	5	435	450	250	690	865	
200L																		318
225S	4,8	356	311	149	55	110	49	225	19	0	19	5	435	450	250	690	865	
225M	2																	60
250M	2	460	349	168	60	53	350	24	24	24	24	6	490	500	300	720	945	
280S	4,6,8																	65
280M	2	457	368	190	75	140	20	67.5	280	24	24	6	545	565	300	790	1010	
280M	4,6,8																	65
315S	2	508	457	216	65	170	22	71	315	28	24	6	640	630	400	1020	1250	
315S	4,6,8,10																	80
315M	2	508	457	216	65	170	22	71	315	28	24	6	640	630	400	1020	1320	
315M	4,6,8,10																	80
315L	2	508	457	216	65	170	22	71	315	28	24	6	640	630	400	1020	1350	
315L	4,6,8,10																	80
355S	2	610	560	254	75	140	20	67.5	355	28	24	6	740	750	1080	1570	1715	
355S	4,6,8,10																	95
355M	2	610	560	254	75	140	20	67.5	355	28	24	6	740	750	1080	1570	1890	
355M	4,6,8,10																	95
355L	2	630	560	254	75	140	20	67.5	355	28	24	6	740	750	1080	1570	2150	
355L	4,6,8,10																	95

单相电容感应电动机

PRODUCT OVERVIEW 产品概述

JY系列单相电容感应电动机广泛应用于空气压缩机、冰箱、医疗器械和其他小型机械设备。该电动机在开启时满负荷启动，启动转矩大，启动电流小。这个系列的电机为全封闭风冷式，0.9,1和2三种帧式大小，可以根据客户要求可制成铸铁或铸铝两种机壳。

JY series single-phase electrical motor is widely used in air compressors, refrigerators, medical apparatus and other small machines which demand full-load starting, a large starting torque and limited starting current.

These series motors are of totally enclosed fan-cooled, and have three frame sizes: 0.9, 1, 2. The frames are made of cast iron or cast aluminum according to the requests.

OPERATING CONDITIONS 使用条件

环境温度: $-15^{\circ}\text{C} < 0 < 40^{\circ}\text{C}$

使用海拔: 不超过 1000m

额定电压: 220V

额定频率: 50Hz/60Hz

防护等级: IP44

绝缘等级: Class B

冷却方式: IC0141

工作制: S1 (持续的)

Ambient temperature: $-15^{\circ}\text{C} < 0 < 40^{\circ}\text{C}$

Altitude: Not exceeding 1000m

Rated voltage: 220V

Rated frequency: 50Hz/60Hz

Protection class: IP44

Insulation Class: Class B

Cooling method: IC0141

Duty: S1 (continuous)



INSTALLATION SIZE 安装尺寸 (mm)

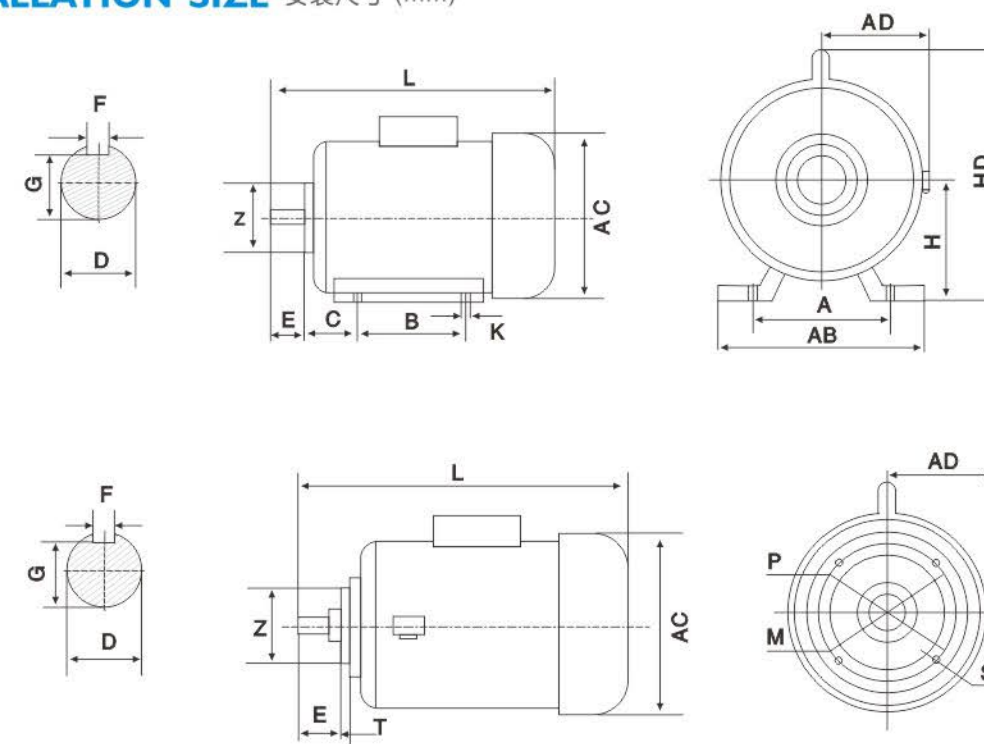

Type 型号	Mounting dimensions 安装尺寸 (mm)														Overall dimensions(mm) 外形尺寸				
	A	B	C	D	E	F	G	H	K	M	N	P	S	T	AB	AC	AD	HD	L
09	125	100	50	14	30	4	11.5	80	10	85	70	105	M8	3	156	156	108	190	330
1	140	100	56	16	40	5	13	90	10	100	80	120	M8	3	176	176	121	220	266
2	160	112	63	19	40	6	15.5	100	12	115	95	140	M8	3	190	190	128	246	258

TECHNICAL DATA 技术参数

Type 型号	Rated Output 功率		Speed 转速 (r/min)	Full Load 全负荷			I _{st} 堵转电流 (A)	堵转转矩 额定转矩 T _{st} /T _n	最大转矩 额定转矩 T _{max} /T _n
	Kw	Hp		Current 电流 (A)	Eff 效率 (%)	Power factor 功率因数 (cosφ)			
JY09B-2	0.18	1/4	2800	1.89	60	0.72	12	1.8	2.2
JY09A-2	0.25	1/3		2.51	63	0.72	15		
JY1B-2	0.37	1/2		3.54	66	0.72	21		
JY1A-2	0.55	3/4		5.26	66	0.72	30		
JY2B-2	0.75	1	2850	6.49	70	0.75	37		
JY2A-2	1.1	1.5		9.15	71	0.77	53		
JY09A-4	0.18	1/4	1400	2.36	56	0.62	12		
JY1B-4	0.25	1/3		3.05	60	0.62	15		
JY1A-4	0.37	1/2		4.24	64	0.62	21		
JY2B-4	0.55	3/4		5.49	67	0.68	29		
JY2A-4	0.75	1		7.27	69	0.68	37		

单相电容感应电动机

单相电容感应电机只需单相电源供电，具有结构简单，成本低廉，噪声比较小等优点，所以广泛应用于电风扇、电冰箱、吸尘器、空调等家用电器和医疗器械的一些小型动力装置中。在市场上，这款电机种类及数量都较多。

Single-phase capacitive electrical motor only needs single-phase power supply, which has the advantages of simple structure, low cost and low noise. Therefore, it is widely used in some small power devices of household appliances and medical devices such as electric fans, refrigerators, vacuum cleaners and air conditioners. In the market, this type of motor type and quantity are more.



TECHNICAL DATA 技术参数

Type 型号	Rated Output 功率		Full Load 全负荷				堵转转矩 额定转矩 T _{st} /T _n	最大转矩 额定转矩 T _{max} /T _n
	Kw	Hp	Speed 转速 (r/min)	Current 电流 (A)	Eff 效率 (%)	Power factor 功率因数 (cosφ)		
MCBV48-2	0.18	1/4	2840	1.9	60	0.72	12	1.8
MCBV48-2	0.25	1/3		2.4	64	0.74	15	
MCBV48-2	0.37	1/2		3.36	65	0.77	21	
MCBV48-2	0.55	3/4		4.65	68	0.79	29	
MCBV56-2	0.55	3/4	2860	4.65	68	0.79	29	
MCBV56-2	0.75	1		6.09	70	0.8	37	
MCBV48-4	0.12	1/6	1440	1.88	50	0.58	9	
MCBV48-4	0.18	1/4		2.49	53	0.62	12	
MCBV48-4	0.25	1/3		3.11	58	0.63	15	
MCBV48-4	0.37	1/2		4.24	62	0.64	21	
MCBV56-4	0.55	3/4		5.49	66	0.69	29	
MCBV56-4	0.75	1		6.87	68	0.73	37	

超大型节能工业风扇

PRODUCT OVERVIEW 产品概述

超大型工业风扇最大直径可达83米,可以驱动大量的空气产生大面积的循环自然风,起到通风降温的双重作用,数台同时工作可产生涡流效应,使用效果更理想。

特点:

厂房通风,人员降温首选产品与传统产品对比节能80%以上大风量,低能耗,无极调速超大覆盖面积,覆盖无死角风感舒适柔和提高工作效率。

适用场合:

广泛应用于工业厂房,物流仓库,公共场所,大型养殖场等大型空间,堪称最佳通风降温解决方案。

Ultra-large industrial fans with a maximum diameter of 83 meters can drive a large amount of air to generate large areas of circulating natural winds. It plays the dual role of ventilation and cooling. Several units work simultaneously can produce eddy current effect and has better application effect.

Characteristic:

Comparing with the traditional products, this products can save more than 80% energy and wind for ventilation and cooling of factory buildings. Big air volume, low energy consumption, infinite speed regulation, super-large coverage area, no dead angle comfort wind can improve work efficiency.

Suitable occasion:

Widely used in industrial plants, logistics warehouses, public places, large farms and other large space. It can be regarded as the best ventilation and cooling solution.



无刷电机

PRODUCT OVERVIEW 产品概述

无刷电机作为动力型电机使用时,同传统电机相比具有显著优势:

- 1、启动扭矩强大,可带负载启动,同时启动电流小,对电源冲击小。
- 2、可以简单方便的实现无级调速,比变频调速电机性能大幅度提高,无刷电机采用闭环控制速度,控制精度高,扭矩强大,特别是相对价格低,有较高的性价比。
- 3、无刷电机采用电子换向,无传统有刷电机的碳刷,无机械磨损,寿命长免维护。
- 4、因为使用钕铁硼稀土永磁材料,无刷电机体积小、重量轻,高效、节能。

Brushless motor as a power-type motor, has significant advantages compared with the traditional motor:

- 1.Large starting torque; can start with load;small current; barely has impacts on the power.
- 2.It is simple and convenient to achieve stepless debugging, and the performance is greater than the frequency control motor. Brushless motor control adopts closed-loop speed, has high control accuracy, high torque.Besides, the motor's relative price is low, and has high cost performance.
- 3.Brushless motor is equipped with electronic commutation brushless. There is no traditional carbon brushes, no mechanical wear and it has long life maintenance.
- 4.The application of the use of ndfeb rare earth permanent magnet materials makes the brushless motor has the characteristics of small size, light weight, high efficiency and energy saving.



TECHNICAL DATA 技术参数

功率 Power (KW)	电压 Voltage (V)	额定电流 Rated current (A)	额定转速 Rated speed (r/min)	额定转矩 Rated torque (N.M)
0.37	220V/50Hz	2.0	3000	1.2
0.55	220V/50Hz	2.8	3000	1.8
0.75	220V/50Hz	3.9	3000	2.4
1.1	220V/50Hz	5.7	3000	3.5
1.5	220V/50Hz	7.8	3000	4.8
2.2	220V/50Hz	11.5	3000	7.0
3.0	220V/50Hz	15.6	3000	9.5
0.37	110V/60Hz	4.0	3000	1.2
0.55	110V/60Hz	5.6	3000	1.8
0.75	110V/60Hz	7.8	3000	2.4
1.1	110V/60Hz	11.4	3000	3.5
1.5	110V/60Hz	15.6	3000	4.8
2.2	110V/60Hz	22.8	3000	7.0
3.0	110V/60Hz	31.2	3000	9.5

THE COLOUR SERIES 色卡

4003 Heather violet	5026 Pearl night blue	6018 Yellow green	1002 Sand yellow	9022 Pearl light grey
4011 Pearl violet	5022 Night blue	6017 May green	1026 Luminous yellow	9007 Grey aluminium
4006 Traffic purple	5013 Cobalt blue	6010 Grass green	1023 Traffic yellow	9006 White aluminium
4008 Signal violet	5002 Ultramarine blue	6001 Emerald green	1018 Zinc yellow	7004 Signal grey
3024 Luminous red	5012 Light blue	6002 Leaf green	1016 Sulfur yellow	7040 Window grey
3018 Strawberry red	5015 Sky blue	6016 Turquoise green	1028 Melon yellow	7042 Traffic grey
3031 Orient red	5017 Traffic blue	6026 Opal green	1007 Daffodil yellow	7011 Iron grey
3024 Raspberry red	5005 Signal blue	6029 Mint green	2000 Yellow orange	7031 Blue grey
3020 Traffic red	5010 Gentian blue	6032 Signal green	2007 Luminous orange	7021 Black grey
3013 Tomato red	5009 Azure blue	6024 Traffic green	2011 Deep orange	9004 Signal black
3000 Flame red	5003 Sapphire blue	6035 Pearl green	2010 Signal orange	9005 Jet black
3001 Signal red	5001 Green blue	6005 Moss green	2009 Traffic orange	9011 Graphite black
3011 Brown red	5000 Violet blue	5021 Water blue	8023 Orange brown	9017 Traffic black

